

M4012 SERIES

DC/DC POWER SUPPLY

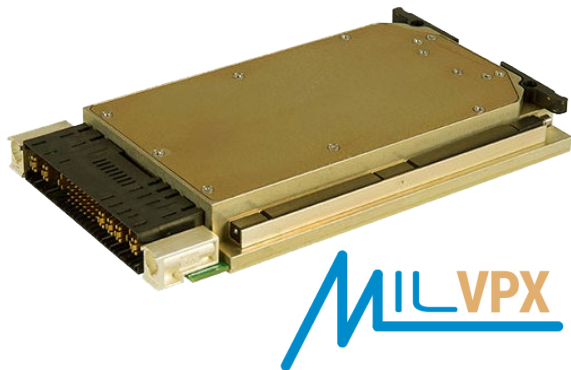

PRODUCT HIGHLIGHTS

- VITA 62 COMPLIANT
- 3U VPX FORM FACTOR
- SIX OUTPUTS
- DC/DC CONVERTER
- 300W
- 180W @ 50mSec HOLDUP
- Input Options:
 - MIL-STD-704
 - MIL-STD-1275
 - DEF-STAN 61-5
- Cyber secure

Applications

Military, Ruggedized, Telecom, Industrial

Special Features

- VITA 62 compliant
- Wide input range
- Remote sense
- Fixed switching frequency (250khz)
- External synchronization capability
- Indefinite short circuit Protection
- Over-voltage shutdown with auto-recovery
- Reverse battery protection
- Over temperature shutdown with auto-recovery
- EMI filters included
- I2C communication

Environmental

Design to Meet MIL-STD-810G

Temperature

Operating: -55°C to +85°C at unit edge

Storage: -55°C to +125°C

Altitude

Method 500.5, Procedure I & II Storage/Air

Transport: 40 Kft

Operation/Air carriage: 70 Kft

Humidity

Method 507.5, Up to 95% RH

Fungus

Does not support fungus growth, in accordance with the guidelines of MIL-STD-454, Requirement 4.

Shock

Method 516.6

40g, 11msec saw-tooth (all directions)

Vibration

Vibration: Figure 514.6E-1. General minimum integrity exposure. (1 hour per axis.)

Salt Fog:

Method 509.5

Reliability: 510,000 Hours, calculated IAW MIL-HDBK-217F Notice 2 at +65 °C, GF.

Note: Environmental Stress Screening (ESS) Including random vibration and thermal cycles is also available. Please consult factory for details.

Electrical Specifications

DC Input

18 to 48 V_{DC}

Max Non-Operating 100V

Options:

- 1) MIL-STD-704 (A-F) Normal and Abnormal Steady State
- 2) MIL-STD-704(A-F) transients Up to 50V, 80V.
- 3) MIL-STD-704(A-F) Transients Under 18V and Starting transients.
- 4) MIL-STD-1275 Surges
- 5) Def Stan 61-5 170V Load Dump.

Efficiency

Up to 85 %

(Full load room temperature)

EMC

Design to meet with MIL-STD 461F(5μH

LISN): CE101, CE102, CS101, CS114,

CS115, CS116

Load Transient Overshoot and

Undershoot

Output dynamic response of less than 5% at load Step of 60%-90%.

Output returns to regulation in less than 1mSec

Ripple and Noise

Typically, less than 50mV_{p-p} (max. 1%_p). Measured across a 0.1μF capacitor and 10μF capacitor on load at Input Voltage of 18V-36V, all Temperature Range.

Communication

I2C protocol available for voltages, currents and temperature for all positive voltages (GAX, SCL, SDA)

DC Output

VS1: 12V, up to 15A

VS2: 3.3V, up to 5A

VS3: 5V, up to 12A

12V_Aux: 12V, up to 1A

-12V_Aux: -12V, up to 1A

3.3V_Aux: 3.3V, up to 5A

Protections

Input

- **Inrush Current Limiter**
Peak value of $5 \times I_{IN}$ for initial inrush currents lasting more than 50 μ Sec.
- **Under Voltage**
Unit shuts down when input steady state voltage drops
Automatic restart when input voltage returns to nominal range.
- **Over Voltage Lock-Out**
Unit shuts down when input steady state voltage rise above $55 \pm 2V_{DC}$.
Automatic restart when input voltage returns to nominal range.

Output

- **Passive or Active over voltage protection on VS2, VS3, 3.3Vaux and -12Vaux**
Transorb, selected at $25\% \pm 5\%$ above nominal voltage, is placed across the output for passive voltage limit.
- **Active over voltage protection on VS1 and 12Vaux**
 $20\% \pm 5\%$ above nominal voltage.
Automatic recovery when output voltage drops below threshold.
- **Overload / Short-Circuit Protection**
VS#: Continuous protection (10-30% above maximum current) for unlimited time (Hiccup). Automatic recovery when overload/short circuit removed.
12Vaux: typical 1.5A to 2A
-12Vaux: typical 2.5A to 3A
3.3Vaux: typical 8A

General

- **Over Temperature Protection**
Automatic shutdown at internal temperature of $95 \pm 5^{\circ}\text{C}$.
Automatic recovery when temperature drops below $90 \pm 5^{\circ}\text{C}$.

Note: Thresholds and protections can be modified / removed (please consult factory)

Functions and Signals - According to VITA 62

Signal No.	Signal Name	Type	Description
1	FAIL*	Output	Indicates to other modules in the system that a failure has occurred in one of the outputs. Please refer to Figure 2 This signal is referenced to SIGNAL RTN .
2	SYSRESET*	Output	Indicates to other modules in the system that all outputs are within their working level. Please refer to Figure 2 This signal is referenced to SIGNAL RTN .
3	INHIBIT*	Input	Controls power supply outputs. This signal in conjunction with INHIBIT controls the outputs. Please refer to Table 1 and Figure 1 This signal is referenced to SIGNAL RTN .
4	ENABLE*	Input	Controls power supply outputs. This signal in conjunction with INHIBIT controls the outputs. Please refer to Table 1 and Figure 1 This signal is referenced to SIGNAL RTN .
5	GA0*, GA1	Input	Used for geographical addressing. GA1 is the most significant bit and GA0 is the least significant bit. This signal is referenced to SIGNAL RTN .
6	SCL, SDA	Bidirectional	I2C bus Clock and Data respectively. Through this bus the voltage and temperature readouts can be shared. This signal is referenced to SIGNAL RTN .
7	REF_CLK	Input	The REF_CLK signal is used to allow the power supply frequency to sync with the system frequency. This signal is referenced to SIGNAL RTN .
8	VOUT SENSE	Input	The SENSE is used to achieve accurate load regulations at load terminals (this is done by connecting the pins directly to the load's terminals).
9	Alert Bit	Output	Indicates to other modules in the system about Holdup event. Please refer to Figure 2 This signal is referenced to SIGNAL RTN .

Table 1 – Inhibit and Enable Functionality

INHIBIT*	Low	Low	High	High
ENABLE*	Low	High	Low	High
VS1, VS2, VS3, ±12VAux	OFF	OFF	ON	OFF
3.3V_AUX	ON	OFF	ON	OFF

Figure 1 – Inhibit and Enable Input stage

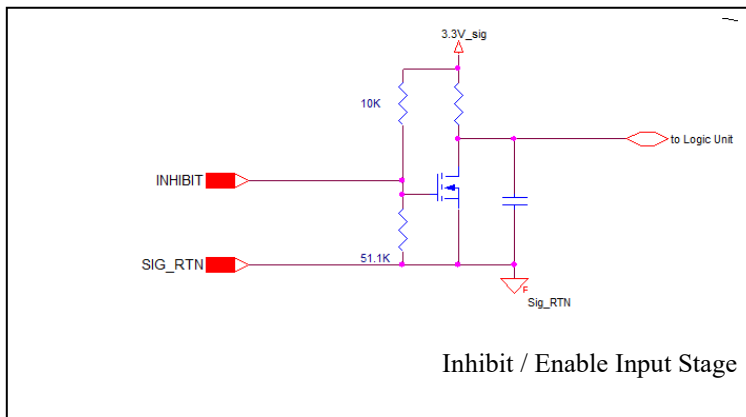
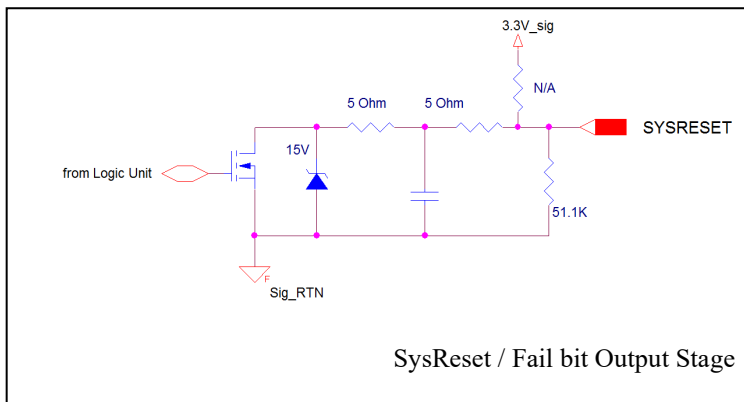

Figure 2 – SysReset and Fail Bit output stage



Detailed Information

1. M4012 Input Voltage Operation.

The M4012 steady state operation voltage is 18V to 48V and will continuously work up to 50V Input line. When Configurable to support MIL-STD 704/1275 transients or surges, the unit will shut down when input voltage rises above 60V or under 16V for more than 2Sec and immediate shut down under 12V or above 100V Input. Power supply automatically recover when it's Input goes back to normal steady state line.

1.1 Low Line Turn-on and Turn-off Limits

To avoid Turn-on and Turn-off glitch the unit have about 2V Hysteresis. The Turn-on threshold is under 20V and turn- off under 18V. Those limits can be adjusted, contact Factory for more information.

2. Outputs Voltage Regulation

The M4012 contains accurate internal sense lines to keep output voltage at less than 4% regulation for all Line/ Load and temperature range (see Table 2).

Output	12V/15A	5V/12A	3.3V/5A	3.3VAux/5A	12VAux/1A	(-)12VAux/1A
Voltage Range	11.85 - 12.15	4.9 - 5.1	3.28 - 3.42	3.2 - 3.4	VS1 - VS1-0.2V	(-)11.8 - (-)12.15

Table 2: Outputs voltage regulation. VIN 18V – 48V, Temperature -55°C – 85°C

2.1. Sense Lines

Sense Lines are provided for VS1, VS2 and VS3 output to compensate line voltage drop. *Sense Lines* proper connection is shown in Figure 3.

Each VSx output has its own *Sense Lines*, additional common *Sense RTN Line* is provided for all VSx Outputs (VITA 62 Standard). Contact Factory for Sense configuration different than the VITA 62 standard

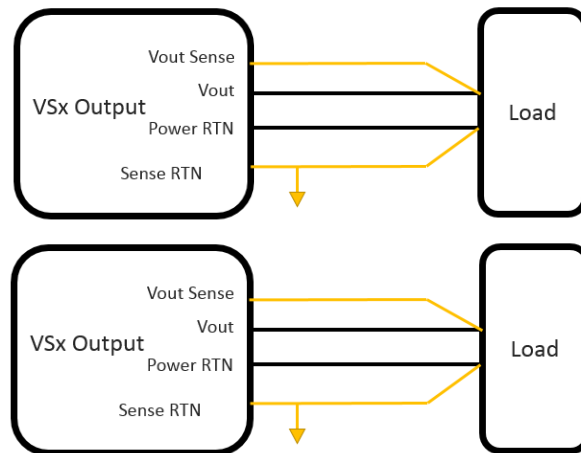

Figure 3: M4012 Sense line connection

3 Output Power

The M4012 can deliver up to 300W steady State at all temperature and input range.

Total Power Output	12V/15A	5V/12A	3.3V/5A	3.3VAux/5A	12VAux/1A	(-)12VAux/1A
---------------------------	----------------	---------------	----------------	-------------------	------------------	---------------------

4 Holdup

Unit can support up to 180W@50mSec Holdup per Mil-STD-704

Holdup capacitor would be Vishay EP1 series or Evans Capacitor TDD3 series.

Higher Holdup is optional. Contact factory.

5 I2C Protocol

Electrical Parameters

Vcc: 3.3VDC
 Pull-up: 10kOhm Input capacitance: 330pf

Slave Device Addressing

- 256 address spaces
- Baud rate: 200kHz maximum
- 7 Bit Protocol
- Support Slot Addressing per VITA 62

Slot Number	MSB							LSB
	A6	A5	A4	A3	A2	A1/*GA1	A0/*GA0	R/W
Slot0	0	1	0	0	0	0	0	
Slot1	0	1	0	0	0	0	1	
Slot2	0	1	0	0	0	1	0	
Slot3	0	1	0	0	0	1	1	

* Slot location is determined by GAx per VITA 62.

Communications Supported

Read Command – 21Hex, deliver 64Bytes of Data. (More commands are available by request)
 The communication starts when the master sends a start followed by the unit slave address, command, checksum and a stop. A second start followed by the slave address and a read will be followed by a 64 Bytes response.

S	Slave Address	R/W	A	Command	A	Check sum	A	P
	A6:A0	0	0	21 Hex	0	DF Hex	0	

S	Slave Address	R/W	A	DATA	A	DATA	A	DATA	A	...	DATA	A	Check sum	N/A	P
	A6:A0	1	0	D7:D0	0	D7:D0	0	D7:D0	0		D7:D0	0	D7:D0	1	

Command – 21Hex read all 64 Bytes
 S – Start
 P – Stop

Master Transmit	Unit Transmit
-----------------	---------------

Memory Space

Response Byte #	Data Type	Meaning	Interpretation	Reading Range
0	U Integer, MSB First	Echo of Command		21 Hex
1		N/A		00 Hex
2-3	S Integer, MSB First	Temperature -55C to 120C	T(C°)=+/- 7bit Dec	-55 C° to 125 C°
3		N/A		00 Hex
4-5	U Integer, MSB First	12V VS1 Voltage	V(out) = Data· m2	20.48V
6-7	U Integer, MSB First	3.3V VS2 Voltage	V(out) = Data· m2	20.48V
8-9	U Integer, MSB First	5V VS2 Voltage	V(out) = Data· m2	20.48V
10-11	U Integer, MSB First	3.3V Aux Voltage	V(out) = Data· m2	20.48V
12-13	U Integer, MSB First	12V Aux Voltage	V(out) = Data· m2	20.48V
14-15	U Integer, MSB First	(-)12V Aux Voltage	V(out) = Data· m2	20.48V
16-17	U Integer, MSB First	12V VS1 Current	V(out) = Data· m3	40A
18-19	U Integer, MSB First	3.3V VS2 Current	V(out) = Data· m3	40A
20-21	U Integer, MSB First	5V VS2 Current	V(out) = Data· m3	40A
22-23	U Integer, MSB First	3.3V Aux Current	V(out) = Data· m4	10A
24-35	U Integer, MSB First	12V Aux Current	V(out) = Data· m5	4A
26-27	U Integer, MSB First	(-)12V Aux Current	V(out) = Data· m5	4A
28-29	U Integer, MSB First	Reserved	00Hex	
30-31	U Integer, MSB First	Reserved	00Hex	
32-51	Character String (ASCII)	Part Number	M4065-xxx* (Note1)	20 Characters
52-53	Decimal, MSB First	Serial Number, 2MSB Dig	X,X Dec (Note2)	N/A TBD
54-55	Decimal, MSB First	Serial Number, 2LSB Dig	X,X Dec (Note2)	N/A TBD
56-57	Decimal, MSB First	Date Code	Week, Year (Note3)	N/A TBD
58-59	Character String (ASCII)	Hardware Rev	B01 & B02 Boards (Note4)	2 Characters
60-61	Decimal, MSB First	Firmware Rev	X,X,X,X Dec (Note5)	4 digits
62	U Integer, MSB First	Reserved		AA Hex
63	U Integer, MSB First	Zero Checksum	Value required to make the sum of bytes 0 to 62 added to a multiple of 256	

Notes:

M2 = 20.48/32767

M3 = 40/32767

M4 = 10/32767

M5 = 4/32767

*Matching unit part number

Notes 1 to 5:

1. Part Number Example: M4465-4

Byte No'	32	33	34	35	36	37	38	39-51
Character	M	4	4	6	5	(-)	4	0
Hex	4D	34	34	36	35	2D	34	00

2. Serial Number Example: 25

Byte No'	52		53		54		55	
Dec Number	0	0	0	0	0	0	2	5
Binary	"0000"	"0000"	"0000"	"0000"	"0000"	"0000"	"0010"	"0101"

3. Date Code Example: week 35 of 2018

Byte No'	56		57	
Dec Number	3	5	1	8
Binary	"0011"	"0101"	"0001"	"1000"

4. Hardware Rev Example: B01 Rev (-), B01 Rev A

Byte No'	58	59
Character	(-)	A
Hex	2D	41

5. Firmware Rev Example: 2.1.0.0

Byte No'	60		61	
Dec Number	2	1	0	0
Binary	"0010"	"0001"	"0000"	"0000"

M4012 SERIES VPX DC/DC POWER SUPPLY

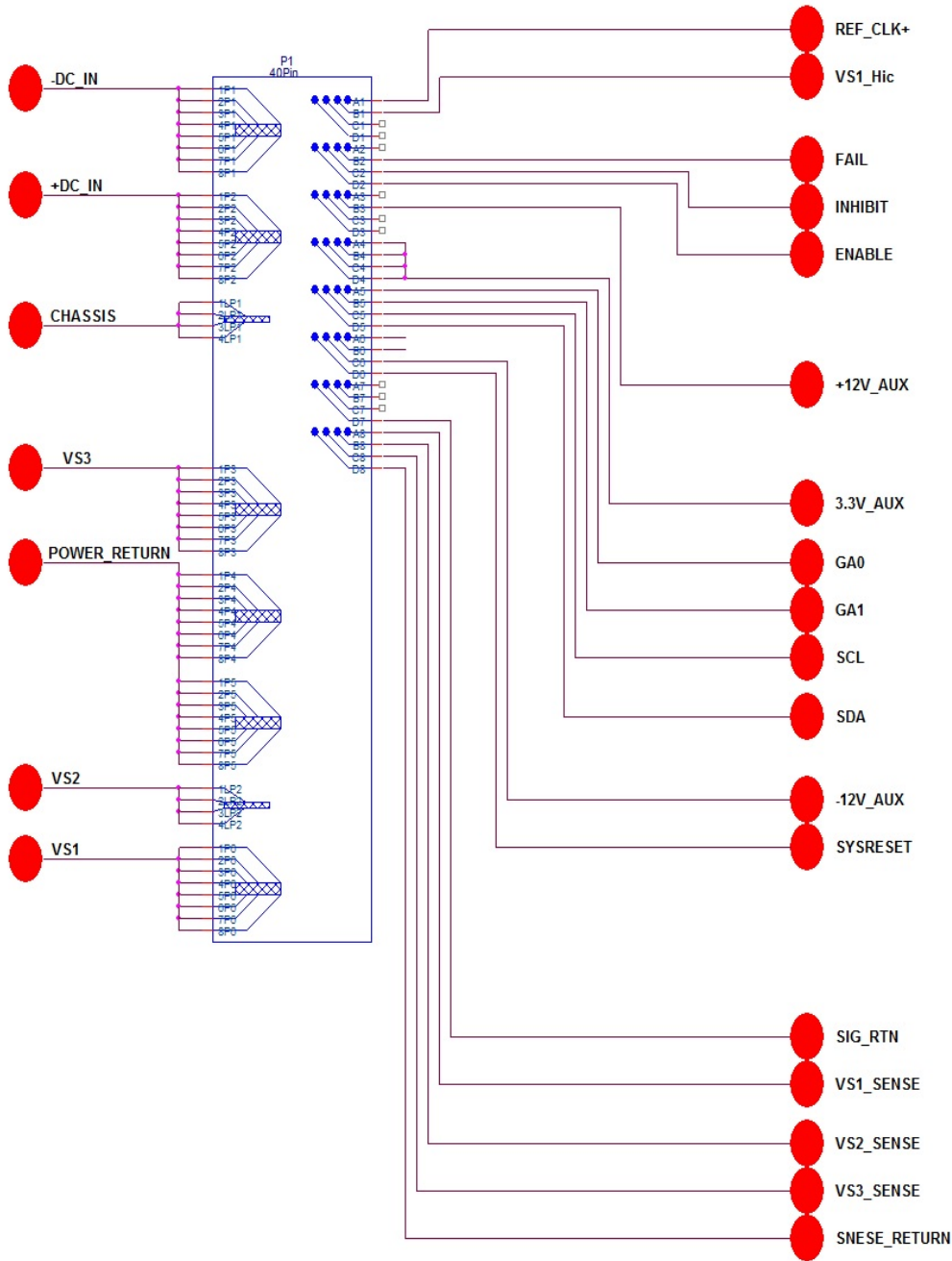

Pin Number	Pin Name
P1	-DC_IN
P2	+DC_IN
LP1	CHASSIS
P3	VS3
P4	POWER_RETURN
P5	POWER_RETURN
LP2	VS2
P6	VS1
A8	VS1_SENSE
B8	VS2_SENSE
C8	VS3_SENSE
D8	SENSE_RETURN
A7	
B7	
C7	
D7	SIG_RTN
A6	N.C
B6	N.C
C6	-12V_AUX
D6	SYSRESET*
A5	GA0*
B5	GA1*
C5	SCL
D5	SDA
A4	+3.3V_AUX
B4	+3.3V_AUX
C4	+3.3V_AUX
D4	+3.3V_AUX
A3	N.C
B3	+12V_AUX
C3	N.C
D3	N.C
A2	N.C
B2	FAIL*
C2	INHIBIT*
D2	ENABLE*
A1	REF_CLK+
B1	
C1	N.C
D1	N.C

Outline Drawing

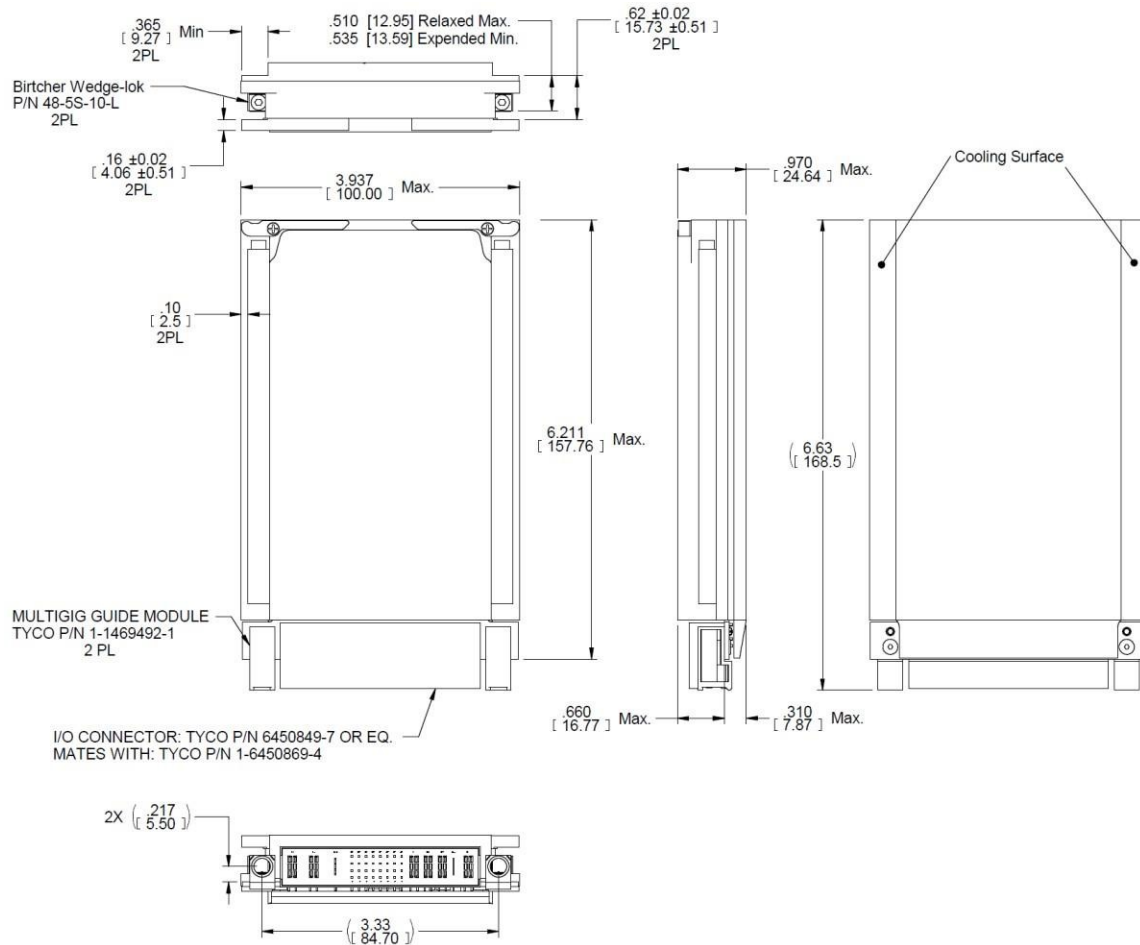

Notes

1. Dimensions are in Inches [mm]
2. Tolerance is:
 - .XX ± 0.02 IN
 - .XXX ± 0.008 IN
3. Weight: Approx. 860 g (30.34) oz
4. 3D model available

Note: Specifications are subject to change without prior notice by the manufacturer