

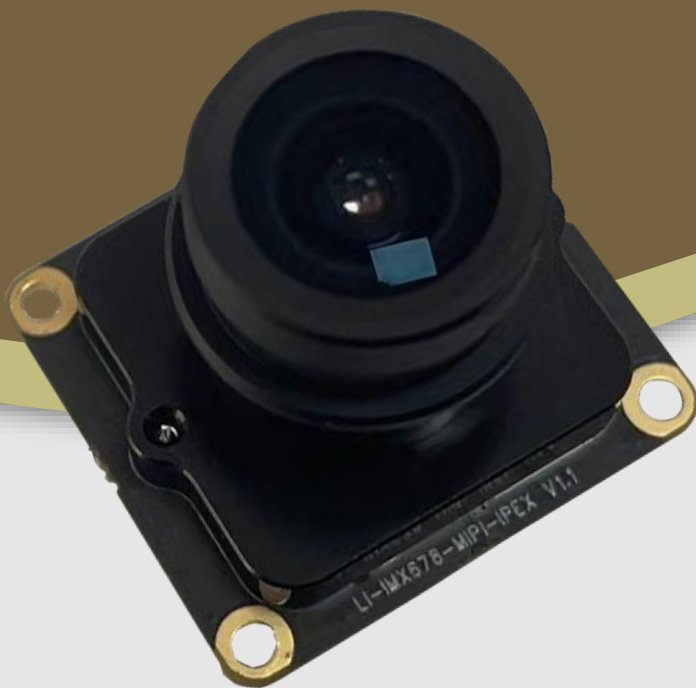

LI-IMX678-MIPI-118H



Address:

910 Auburn Ct
Fremont, CA 94538
USA



Phone:

+1 (408)263-0988

Fax:

+1 (408)217-1960



Sales:

sales@leopardimaging.com

Support:

support@leopardimaging.com

INTRODUCTION

The LI-IMX678-MIPI-118H is a MIPI CSI-2 camera with Sony diagonal 8.86 mm (Type 1/1.8) STARVIS2 CMOS color sensor IMX678 which has low power consumption and achieves high sensitivity, low dark current and no smear. This camera outputs RAW data.

SPECIFICATIONS

Sensor	Sony Diagonal 8.86 mm STARVIS2 CMOS Sensor IMX678
Optical Format	1/1.8"
Resolution	3856 (H) x 2176 (V) (active pixels)
Pixel Size	2.0 x 2.0 μm
Output Format	10-bit / 12-bit RAW data
Maximum Frame Rate	60 fps @ all-pixel scan mode
HDR (High Dynamic Range)	Supported
ISP	Not included
Color / Mono	Color sensor
Interface	4-lane MIPI CSI-2
Power Consumption	Approx. 0.6W
Operating Temp	TBD
Storage Temp	TBD
Weight	~ 17 g
Part#	LI-IMX678-MIPI-118H

APPLICATIONS

- IoT
- Drone
- Robots

LENS SPECIFICATIONS

Effective Focal Length	4.063 mm
Aperture, F/#	2.29 \pm 5%
Field of View (FOV)	118° horizontal
Optical Distortion	-28.1%
TV Distortion	-9.3%
Relative Illumination	59.1%
IR Filter	650 nm IR cut filter
Lens Mount	M12 x 0.5

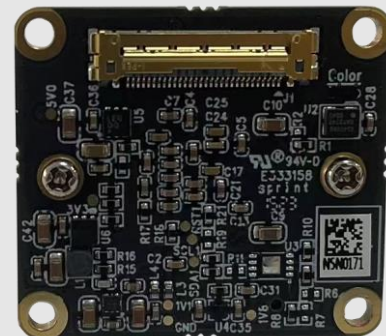

DIMENSIONS

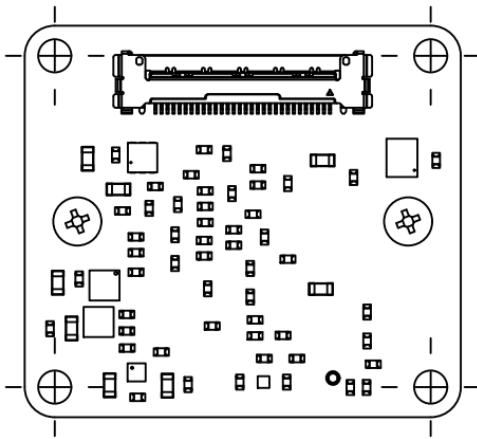
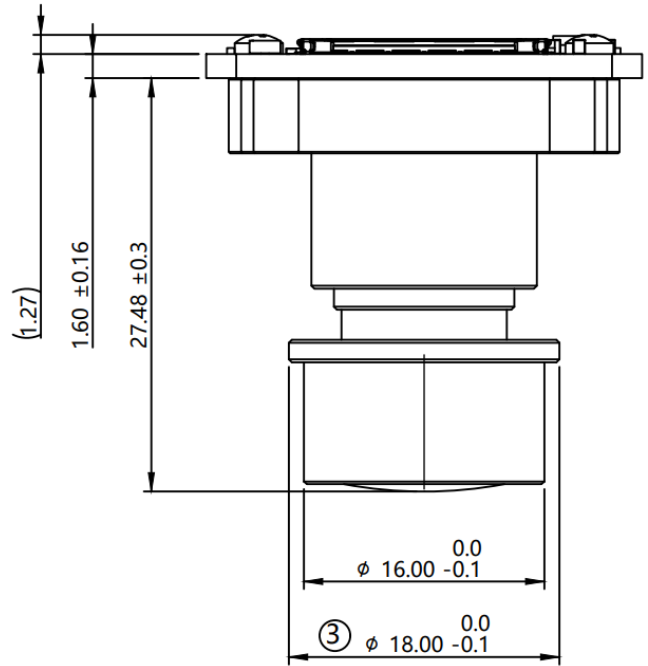
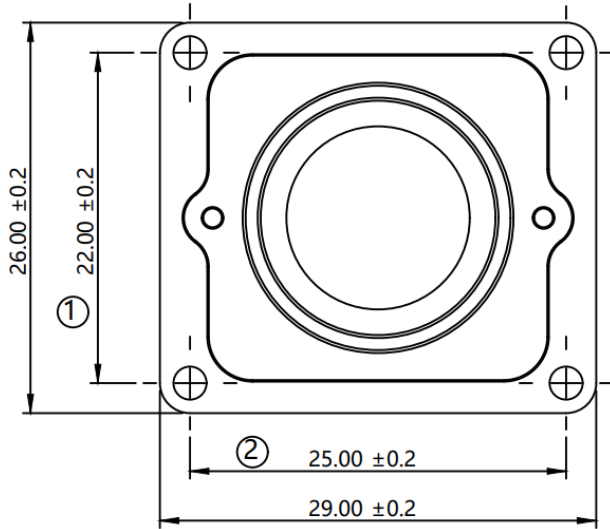

TOLERANCE TABLE					
LENGTH TOLERANCE		CHAMFER TOLERANCE		ANGLE TOLERANCE	
Size X	Tolerance	Size X	Tolerance	Size X	Tolerance
0.5 < X ≤ 3	±0.1	0.5 < X ≤ 3	±0.2	X ≤ 10	±1°
3 < X ≤ 6	±0.1	3 < X ≤ 6	±0.5	10 < X ≤ 50	±30'
6 < X ≤ 30	±0.2	6 < X ≤ 30	±1	50 < X ≤ 120	±20'
30 < X ≤ 120	±0.3	X > 30	±2	120 < X ≤ 400	±10'
120 < X ≤ 400	±0.5			X > 400	±5'
400 < X ≤ 1000	±0.8				
X > 1000	±1.2				

NOTE:

- ⊗ marked are important sizes.
- Other unmarked tolerances - refer to the Tolerance table.

Unit: mm

INTERFACE J1

- Connector Part#: 20525-030E-02
- Number of Positions: 30
- Pitch: 0.4 mm
- Mating I-PEX cable: LI-FAW-1233
- Sensor I2C Address: 0x1A (7-bit)
- External Power Supply: 3.3V, 5.0V
- 3.3V (analog), 1.8V and 1.1V are generated from board

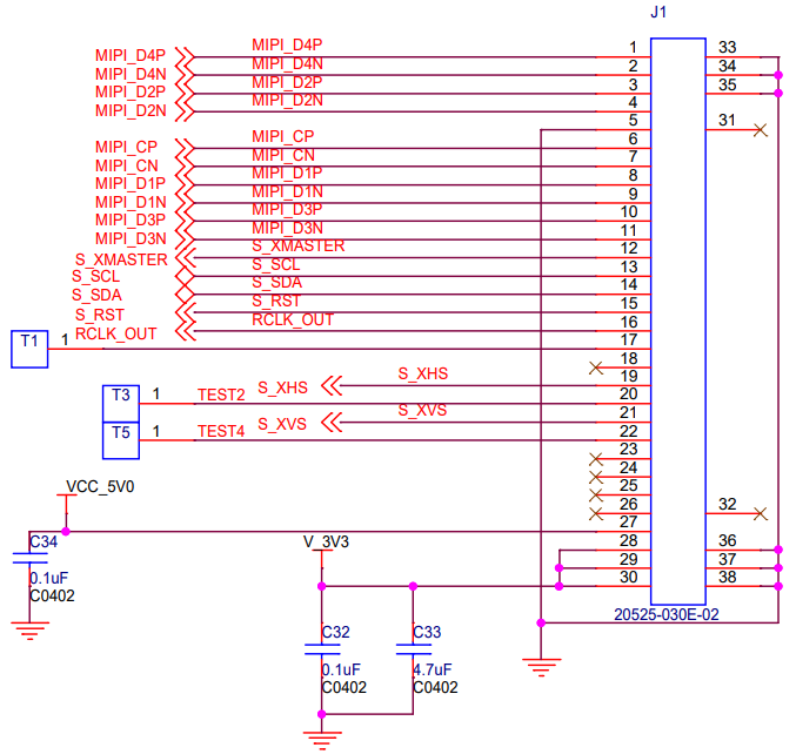

● REVISION HISTORY

Revision	Description	Release Date
0.1	Initial draft.	31 May 2023
0.2	Updated power consumption.	04 Jul 2023

910 Auburn Ct, Fremont, CA 94538, USA

Phone: +1-408-263-0988

Fax: +1-408-217-1960

Email: sales@leopardimaging.com

Website: www.leopardimaging.com

