

FW30 series

30 Watt AC Adapter

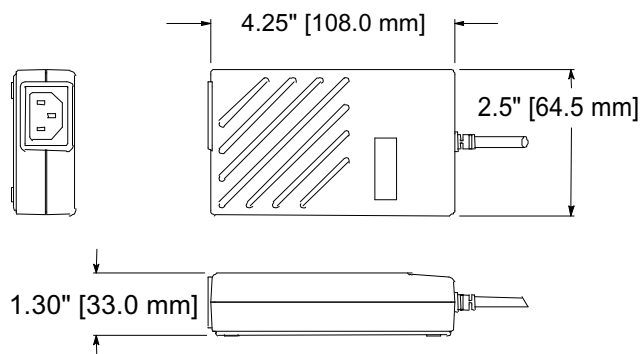

Features

- Wide range AC input
- Fully regulated output
- High efficiency
- 5 year warranty
- RoHs compliant version available

Environmental

- Operating temperature..... 0° C to 40° C
- Storage temperature..... -55° C to 85° C
- Weight = 0.7 lbs

EMI

Meets FCC class B, CISPR 22 class B

Safety

- UL UL1950
- cUL CSA 22.2 NO. 950
- Nemko EN 60950
- CE Marked

Polarity



Ordering Information

- FW = Series
- 30 = Watts DC Output
- XX = Voltage DC Output
- 760 = Output Connector (options available)
- F = RoHs Compliant
- NC = No AC Input Cord (options available)

Electrical Specifications

Input

- Voltage..... 100 - 240 VAC
- Current..... 1.0 Amp @ 100 VAC
- Frequency..... 47 - 63 Hz
- AC cord..... Optional
- Input connector..... 3 Pin IEC 320 input receptacle

Output

- Line regulation..... TYP +/- 1%
- Load regulation..... TYP +/- 5%
- Set point..... +/- 3% at 60% load
- Hold up time..... 20 ms min at full load, 115 VAC
- Over voltage protection..... Built-in
- Over current protection..... Built-in
- Short circuit protection..... Pulsing mode, auto recovery
- Efficiency..... 80% min at full load and 115 VAC
- Transient response..... 2 ms for 50% load change typical
- Ripple/noise (V_{p-p})..... +/- 1% (20 MHz bandwidth)
- Output connector..... Barrel type (5.5 x 2.5 x 9.5 mm)

Model No.	Voltage	Power	Current
FW3012-760-NC FW3012-760F-NC	12V	30W	2.5A
FW3015-760-NC FW3015-760F-NC	15V	30W	2.0A
FW3018-760-NC FW3018-760F-NC	18V	30W	1.67A
FW3024-760-NC FW3024-760F-NC	24V	30W	1.25A