

BORA

ARM Cortex-A9 + FPGA CPU Module

ULTRA Line

HARDWARE MANUAL

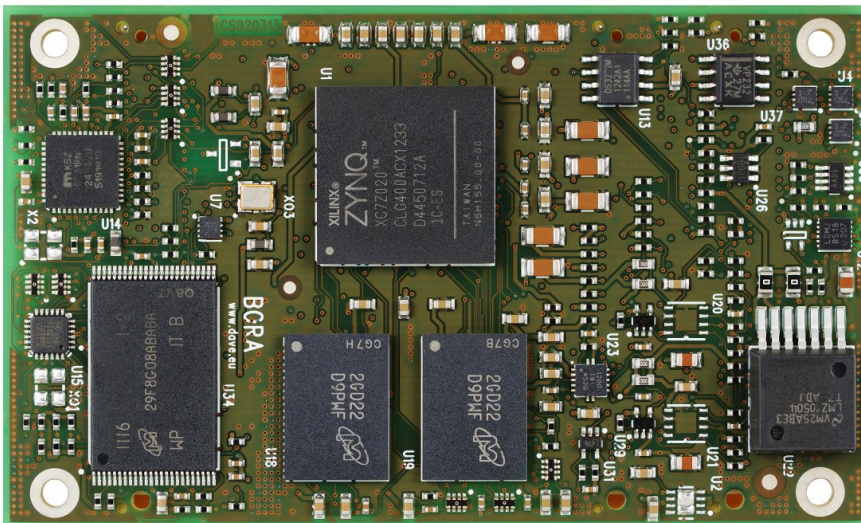

<Page intentionally left blank>

Table of Contents

1	Preface.....	6
1.1	About this manual.....	6
1.2	Copyrights/Trademarks.....	6
1.3	Standards.....	6
1.4	Disclaimers.....	6
1.5	Warranty.....	6
1.6	Technical Support.....	7
1.7	Related documents.....	8
1.8	Conventions, Abbreviations, Acronyms.....	8
2	Introduction.....	10
2.1	Product Highlights.....	12
2.2	Block Diagram.....	13
2.3	Feature Summary.....	18
3	Design overview.....	20
3.1	Xilinx Zynq™-7000 SoC.....	20
3.2	DDR3 memory bank.....	22
3.3	NOR flash bank.....	22
3.4	NAND flash bank.....	22
3.5	Integrated FPGA.....	23
3.6	Memory Map.....	23
3.7	Power supply unit.....	23
3.8	CPU module connectors.....	24
4	Mechanical specifications.....	25
4.1	Board Layout.....	25
4.2	Connectors.....	27
5	Power, reset and control.....	28
5.1	Power Supply Unit (PSU) and recommended power-up sequence.....	28
5.1.1	XCN15034 and power-off sequence.....	29
5.2	Reset.....	31
5.2.1	MRST (J2.116).....	32
5.2.2	PORSTn (J2.114).....	32
5.2.3	SYS_RSTn (J2.112).....	32
5.2.4	PS_MIO51_501 (J2.106).....	32
5.2.5	PS_MIO50_501 (J2.104).....	33
5.3	Voltage monitor.....	33
5.4	System boot.....	33
5.4.1	Boot modes.....	34
5.4.2	Default boot configuration.....	35
5.4.3	Boot sequence customization.....	35
5.5	Clock scheme.....	36
5.6	Recovery.....	36

5.6.1	JTAG Recovery.....	36
5.6.2	SD/MMC Recovery.....	37
5.7	Multiplexing.....	37
5.8	RTC.....	37
5.9	Watchdog.....	38
5.9.1	Selecting different configurations.....	39
5.10	Thermal IC.....	40
6	Pinout table.....	41
6.1	Carrier board mating connector J1.....	42
6.2	Carrier board mating connector J2.....	47
6.3	Carrier board mating connector J3.....	52
7	Peripheral interfaces.....	58
7.1	Notes on pin assignment.....	58
7.2	PS interfaces.....	59
7.2.1	Gigabit Ethernet.....	59
7.2.2	USB.....	60
7.2.3	Quad-SPI.....	61
7.2.4	Static memory controller (NAND).....	61
7.2.5	I ² C0.....	62
7.2.6	SD/SDIO.....	62
7.2.7	UART1.....	63
7.2.8	CAN.....	63
7.2.9	JTAG.....	64
7.3	PL interfaces.....	64
7.3.1	FPGA Bank 34.....	66
7.3.2	FPGA Bank 35.....	69
7.3.2.1	Differential pairs.....	71
7.3.2.2	Single-ended signals.....	71
7.3.2.3	FDDR_ADDR class.....	72
7.3.2.4	FDDR_CK class.....	74
7.3.2.5	FDDR_BYTE0 class.....	75
7.3.2.6	FDDR_BYTE1 class.....	76
7.3.2.7	VREF.....	77
7.3.2.8	Related Xilinx documentation.....	77
7.3.3	FPGA Bank 13 (Zynq 7020 only).....	78
8	Carrier board design guidelines.....	81
8.1	Suggested PCB specifications.....	81
8.2	Power rails.....	81
8.3	Main SD/MMC interface.....	82
8.4	Main Gigabit Ethernet interface (ETH0).....	82
8.5	CAN interface.....	82
8.6	XADC interface.....	83

9	Operational characteristics.....	84
9.1	Maximum ratings.....	84
9.2	Recommended ratings.....	84
9.3	Power consumption.....	84
9.3.1	Testbed 1.....	84
9.3.1.1	Results.....	85
9.3.2	Testbed 2.....	86
9.3.2.1	Results.....	86
9.4	Heat Dissipation.....	87
10	Application notes.....	88

Index of Tables

Tab. 1:	Related documents.....	8
Tab. 2:	Abbreviations and acronyms used in this manual.....	8
Tab. 3:	CPU, Memories, Buses.....	17
Tab. 4:	Peripherals.....	17
Tab. 5:	FPGA specifications.....	18
Tab. 6:	Electrical, Mechanical and Environmental Specifications.....	18
Tab. 7:	XC7-Z0x0 comparison.....	20
Tab. 8:	DDR3 specifications.....	21
Tab. 9:	NOR flash specifications.....	21
Tab. 10:	NAND flash specifications.....	22

Illustration Index

Fig. 1:	BORA – Powered by Zynq processor.....	10
Fig. 2:	BORA – Dual ARM Cortex A9 plus FPGA.....	10
Fig. 3:	BORA SOM (top view).....	12
Fig. 4:	Board layout - Top view.....	24
Fig. 5:	Board layout - Side view.....	25
Fig. 6:	Connectors layout.....	26

1 Preface

1.1 About this manual

This Hardware Manual describes the BORA CPU module design and functions.

Precise specifications for the Xilinx Zynq processor can be found in the CPU datasheets and/or reference manuals.

1.2 Copyrights/Trademarks

Ethernet® is a registered trademark of XEROX Corporation.

All other products and trademarks mentioned in this manual are property of their respective owners.

All rights reserved. Specifications may change any time without notification.

1.3 Standards

DAVE Embedded Systems is certified to ISO 9001 standards.

1.4 Disclaimers

DAVE Embedded Systems does not assume any responsibility about availability, supplying and support regarding all the products mentioned in this manual that are not strictly part of the BORA CPU module.

BORA CPU Modules are not designed for use in life support appliances, devices, or systems where malfunction of these products can reasonably be expected to result in personal injury.

DAVE Embedded Systems customers who are using or selling these products for use in such applications do so at their own risk and agree to fully indemnify **DAVE Embedded Systems** for any damage resulting from such improper use or sale.

1.5 Warranty

BORA is warranted against defects in material and workmanship for the warranty period from the date of shipment. During the

warranty period, **DAVE Embedded Systems** will at its discretion decide to repair or replace defective products. Within the warranty period, the repair of products is free of charge as long as warranty conditions are observed.

The warranty does not apply to defects resulting from improper or inadequate maintenance or handling by the buyer, unauthorized modification or misuse, operation outside of the product's environmental specifications or improper installation or maintenance.

DAVE Embedded Systems will not be responsible for any defects or damages to other products not supplied by **DAVE Embedded Systems** that are caused by a faulty BORA module.

1.6 Technical Support

We are committed to making our product easy to use and will help customers use our CPU modules in their systems. Technical support is delivered through email to our valued customers.

Support requests can be sent to support-bora@dave.eu.

Software upgrades are available for download in the restricted access download area of **DAVE Embedded Systems** web site: <http://www.dave.eu/reserved-area>. An account is required to access this area and is provided to customers who purchase the development kit (please contact support-bora@dave.eu for account requests).

Please refer to our Web site at <http://www.dave.eu/dave-cpu-module-zynq-bora.html> for the latest product documentation, utilities, drivers, Product Change Notifications, Board Support Packages, Application Notes, mechanical drawings and additional tools and software.

1.7 Related documents

Document	Location
DAVE Embedded Systems Developers Wiki	http://wiki.dave.eu/index.php/Main_Page
Zynq-7000 Technical Reference Manual	http://www.xilinx.com/support/documentation/user_guides/ug585-Zynq-7000-TRM.pdf
Zynq-7000 All Programmable SoC Packaging and Pinout	http://www.xilinx.com/support/documentation/user_guides/ug865-Zynq-7000-Pkg-Pinout.pdf

Tab. 1: Related documents

1.8 Conventions, Abbreviations, Acronyms

Abbreviation	Definition
BELK	BORA Embedded Linux Kit
FSBL	First stage bootloader
GPI	General purpose input
GPIO	General purpose input and output
GPO	General purpose output
PCB	Printed circuit board
PL	Zynq Programmable Logic
PS	Zynq Processing System
RTC	Real time clock
SOM	System on module
TRM	Technical Reference Manual

Tab. 2: Abbreviations and acronyms used in this manual

Revision History

Version	Date	Notes
0.9.0	July 2013	First Draft
1.0.0	July 2013	First Release
1.0.1	May 2014	Updated block diagram Updated pinout table Updated Sections 5.1 and 5.2 Updated Section 7 (MIO mapping, SD/ MMC, UART, I ² C) Added info on differential pairs Added "Carrier board design guidelines" Section Minor fixes
1.0.2	August 2014	Fixed PGOOD description Fixed power-up sequence diagram Minor fixes
1.0.3	February 2015	Updated mechanical drawings for Rev. B SOM Updated information on VDDIO_BANK13 pins Minor fixes
1.0.4	September 2015	Added info on thermal IC Minor fixes Released with BELK 2.2.0
1.0.5	March 2016	Updated watchdog and power sequence information Minor fixes Released with BELK 3.0.0
1.0.6	November 2020	Update Power Consumption and Heat dissipation

2 Introduction

BORA is the new top-class Dual Cortex-A9 + FPGA CPU module by **DAVE Embedded Systems**, based on the recent Xilinx Zynq XC7Z010/XC7Z020 application processor.

Thanks to BORA, customers are going to save time and resources by using a compact solution that **includes both a CPU and an FPGA**, avoiding complexities on the carrier PCB.

The use of this processor

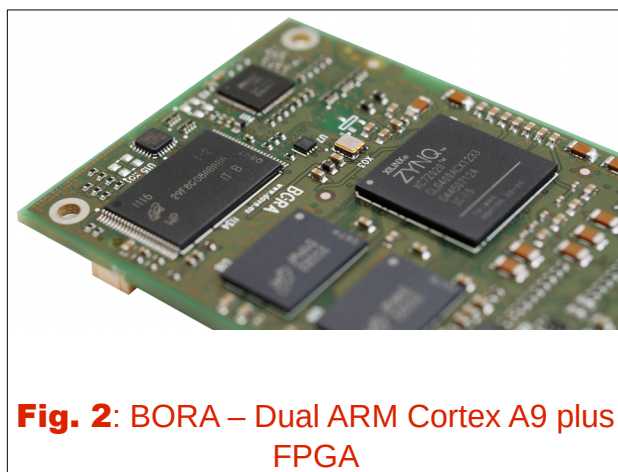

enables extensive system-level differentiation of new applications in many industry fields, where high performances and extremely compact form factor (85mm x 50mm) are key factors. Smarter system designs are made possible, following the trends in functionalities and interfaces of the new, state-of-the-art

embedded products. BORA offers great computational power, thanks to the rich set of peripherals, the Dual Cortex-A9 and the Artix-7 FPGA together with a large set of high-speed I/Os (up to 5GHz).

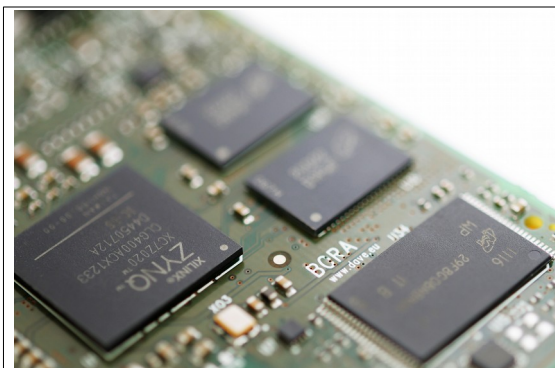

BORA enables designers to create rugged products suitable for harsh mechanical and thermal environments, allowing the development of the most advanced and robust products.

Thanks to the tight integration between the ARM-based processing system and the on-chip programmable logic, designers are free to add virtually any peripheral or create custom accelerators that extend system performance and better match specific application requirements.

BORA is designed and manufactured according to **DAVE Embedded Systems ULTRA Line** specifications, in order to guarantee premium quality and technical value for customers who require top performances and flexibility. BORA is suitable for high-end applications such as medical instrumentation, advanced communication systems, critical real-time operations and safety applications.

2.1 Product Highlights

- Unmatched performance thanks to dual ARM Cortex-A9 @ 800 MHz
- All memories you need: on-board NOR and NAND Flash
- Enabling smarter system thanks to Artix-7 FPGA integrated on chip
- FPGA banks wide range PSU input from 1.2V to 3.3V
- Highest security and reliability: internal voltage monitoring and power good enable
- Reduced carrier complexity: dual CAN, USB, Ethernet GB and native 3.3V I/O
- Easy to fit thanks to its small form factor
- Precise timing application thanks to on-board 5ppm RTC

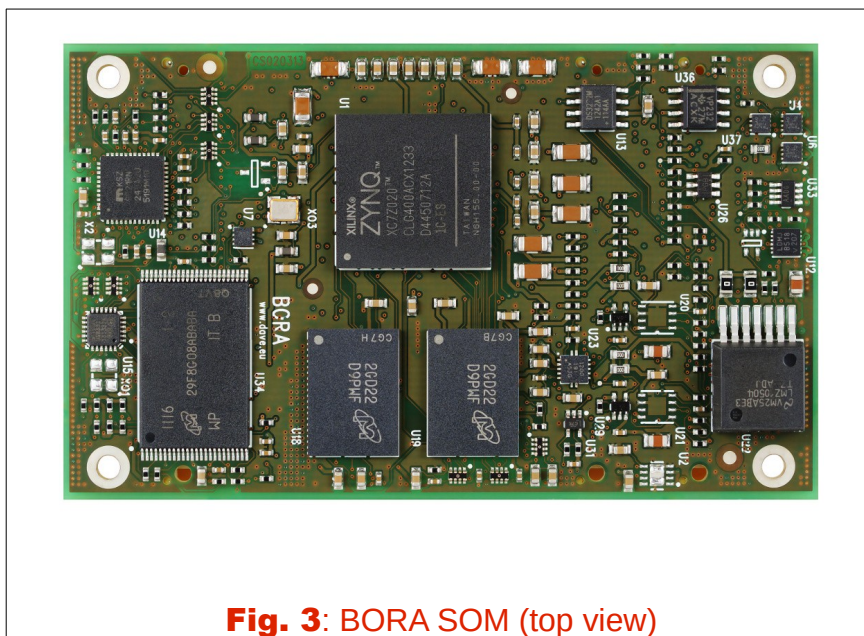

2.2 Block Diagram

To understand BORA block diagram it is necessary to briefly describe Zynq essential structure and routing scheme. For more details please refer to section 5.7 on page 37 where Xilinx's documentation references are listed.

Zynq is composed by two main blocks: the ARM Cortex-A9 dual-core subsystem - denoted as PS - and the FPGA subsystem - denoted as PL. Besides ARM processors, PS includes some native peripherals such as Gigabit Ethernet MAC controllers, USB controllers etc. PS is fully autonomous, meaning that, no matter if the PL is programmed, it is able to boot as if it was a traditional processor.

From the I/O standpoint, PS has several pads providing flexible multiplexing of native peripherals. These pads are denoted as MIOs and are grouped in some banks denoted as PS 50x.

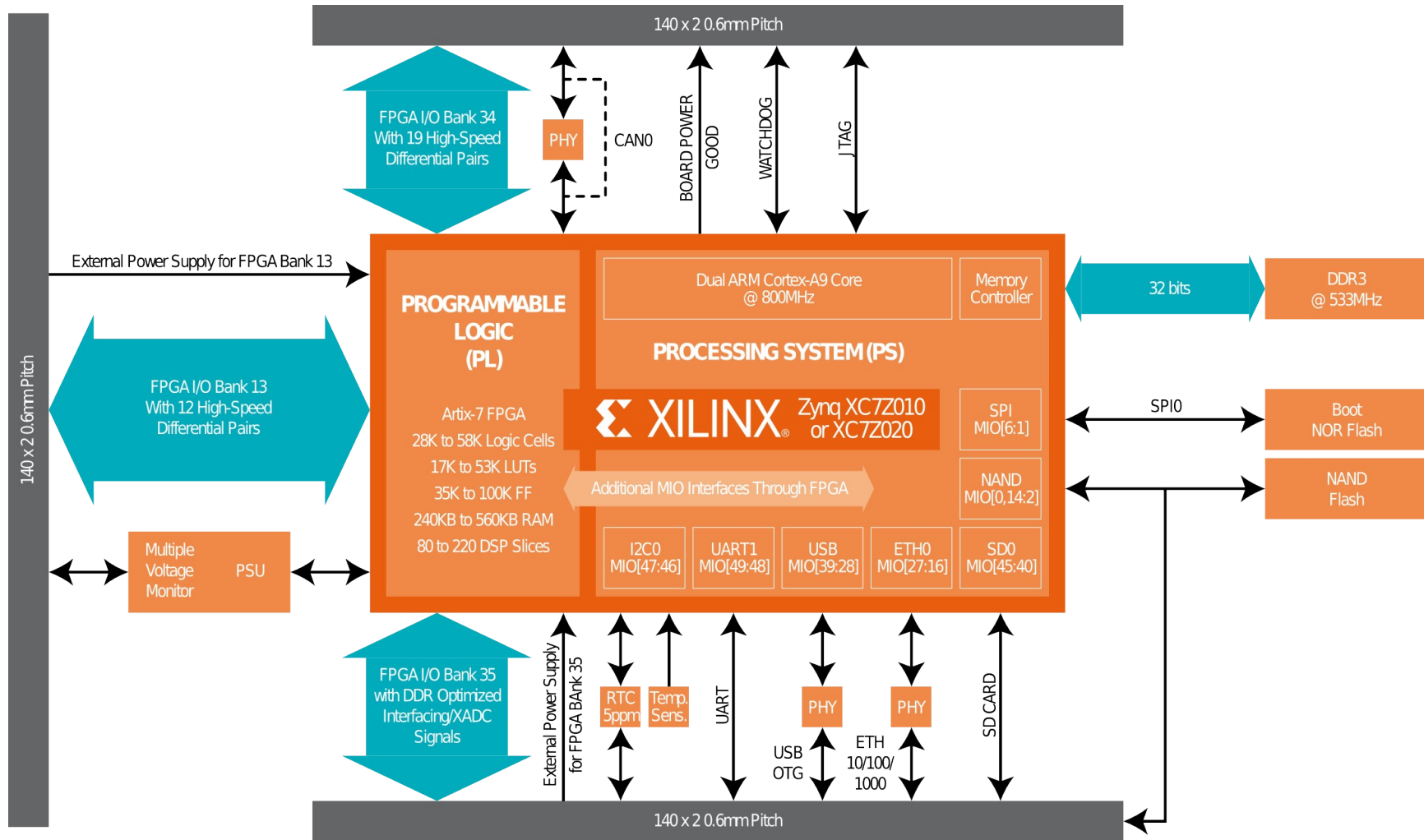

On the other side, PL subsystem provides a lot of configurable I/Os, grouped in banks denoted as Bank x (eg Bank 9, Bank 13 etc.). Two types of such banks exist: HR¹ and HP². Some of the MIO signals can be routed outside the component via PL subsystem. This technique is called EMIO routing.

The block diagram shows the basic internal interconnections of BORA SoM.

On PS side, the following peripherals and devices are connected to MIO signals:

- Serial NOR flash (MIO [6:1])
- NAND flash (MIO [0], [14:2])
- UART1 (MIO [49:48])
- I2C temperature sensor (MIO [47:46])
- I2C MEMS RTC (MIO [47:46])
- Gigabit Ethernet PHY (MIO [27:16])
- USBOTG PHY (MIO [39:28])
- SD/MMC (MIO [45:40])

Since these devices are considered essential, they have been connected to MIO signals in order to make them always functional, even if PL is not programmed. These peripherals represent the default configuration for the BORA SOM, but other configurations can be implemented changing the pin multiplexing (please refer to section 5.7 on page 37).

Please note that serial NOR flash and NAND flash share some signals. Software drivers need to

1 HR: high range I/O with support for I/O voltage from 1.2V up to 3.3V.

2 HP: high performance I/O with support for I/O voltage from 1.2V up to 1.8V.

properly handle this configuration to avoid misuse of these devices.

On PL side, the following devices are connected to I/O signals:

- CAN transceiver (IO_L6P_T0_34, IO_L19P_T3_34).

Any of the CAN controllers of PS subsystem can be connected to CAN transceiver via EMIO routing with no limitations.

2.3 Feature Summary

Feature	Specifications	Options
CPU	Xilinx Dual ARM Cortex-A9 ZYNQ XC7Z010/XC7Z020 @ 800MHz	
Cache	L1: 32Kbyte instruction, 32Kbyte data L2: 512Kbyte for each core	
RAM	DDR3 SDRAM @ 533 MHz Up to 1 GB	
SRAM	On-chip RAM, 256 KB	
Storage	Flash NOR SPI (8, 16, 32 MB) Flash NAND (all sizes, on request)	

Tab. 3: CPU, Memories, Buses

Feature	Specifications	Options
Coprocessors	NEON™ & Single / Double Precision Floating Point for each processor	
USB	Up to 2x 2.0 OTG ports	
UARTs	Up to 2x UART ports	
GPIO	Up to x lines, shared with other functions (interrupts available)	
Networks	Gigabit Ethernet 10/100/1000 Mbps Additional GMII/MII interface	
CAN	2x full CAN 2.0B compliant interfaces	
SD/MMC	2x SD/SDIO 2.0/MMC 3.31 compliant controllers	
Serial buses	2x full-duplex SPI ports with three peripheral chip selects 2xmaster and slave I ² C interfaces	
Timers	2x triple timers/counters (TTC)	
RTC	On board (DS3232), external battery powered	
Debug	JTAG IEEE 1149.1 Test Access Port CoreSight™ and Program Trace Macrocell (PTM)	

Tab. 4: Peripherals

Feature	Specifications	Options
FPGA model	Artix™-7	
Logic cells	28K to 56K	
LUTs	17K to 53K	
Flip flops	35K to 100K	
RAM	240KB to 560KB	
DSP slices	80 to 220	
Differential pairs	Up to 34 differential pairs for high freq. interfaces	

Tab. 5: FPGA specifications

Feature	Specifications	Options
Supply Voltage	3.3V ±5%, on-board voltage regulation	
Active power consumption	See section 9.3 - Power consumption	
Dimensions	85mm x 50mm	
Weight	<tbd>	
MTBF	<tbd>	
Operating temperature range	Commercial: 0°C / +70°C Industrial: -40°C / +85°C	
Shock	<tbd>	
Vibration	<tbd>	
Connectors	3 x 140 pins 0.6mm pitch	
Connectors insertion/removal	<tbd>	

Tab. 6: Electrical, Mechanical and Environmental Specifications

3 Design overview

The heart of BORA module is composed by the following components:

- Xilinx Zynq Z-7010 (XC7Z010) / Z-7020 (XC7Z020) SoC
- Power supply unit
- DDR memory banks
- NOR and NAND flash banks
- 3x 140 pin connectors with interfaces signals

This chapter shortly describes the main BORA components.

3.1 Xilinx Zynq™-7000 SoC

The Zynq™-7000 family is based on the Xilinx Extensible Processing Platform (EPP) architecture. These products integrate a feature-rich dual-core ARM® Cortex™-A9 based processing system (PS) and 28 nm Xilinx programmable logic (PL) in a single device. The ARM Cortex-A9 CPUs are the heart of the PS and also include on-chip memory, external memory interfaces, and a rich set of peripheral connectivity interfaces.

The Zynq-7000 family offers the flexibility and scalability of an FPGA, while providing performance, power, and ease of use typically associated with ASIC and ASSPs. The range of devices in the Zynq-7000 AP SoC family enables designers to target cost-sensitive as well as high-performance applications from a single platform using industry-standard tools. While each device in the Zynq-7000 family contains the same PS, the PL and I/O resources vary between the devices. As a result, the Zynq-7000 AP SoC devices are able to serve a wide range of applications including:

- Automotive driver assistance and driver information
- Infotainment
- Broadcast camera
- Industrial motor control and industrial networking

- Machine vision
- IP and Smart camera
- LTE radio and baseband
- Medical diagnostics and imaging
- Multifunction printers
- Video and night vision equipment

The Zynq-7000 AP SoC is composed of the following major functional blocks:

- Processing System (PS)
 - Application processor unit (APU)
 - Memory interfaces
 - I/O peripherals (IOP)
 - Interconnect
- Programmable Logic (PL)

The processors in the PS always boot first, allowing a software centric approach for PL system boot and PL configuration. The PL can be configured as part of the boot process or configured at some point in the future. Additionally, the PL can be completely reconfigured or used with partial, dynamic reconfiguration (PR). PR allows configuration of a portion of the PL. This enables optional design changes such as updating coefficients or time-multiplexing of the PL resources by swapping in new algorithms as needed.

BORA can mount two versions of the Zynq processor. The following table shows a **comparison** between the processor models, highlighting the differences:

SoC	Programmable logic cells	LUTs	Flip-flops	Extensible block RAM	DSP slices	Peak DSP performance
XC7Z010	28K Logic Cells	17600	35200	240 KB	80	58 GMACs
XC7Z020	85K Logic Cells	53200	106400	560 KB	220	158 GMACs

Tab. 7: XC7-Z0x0 comparison

3.2 DDR3 memory bank

DDR3 SDRAM memory bank is composed by 2x 16-bit width chips resulting in a 32-bit combined width bank.

The following table reports the SDRAM specifications:

CPU connection	SDRAM bus
Size min	512 MB
Size max	1 GB
Width	32 bit
Speed	533 MHz

Tab. 8: DDR3 specifications

3.3 NOR flash bank

NOR flash is a Serial Peripheral Interface (SPI) device. This device is connected to the Quad-SPI channel 0 and by default it acts as boot memory.

The following table reports the NOR flash specifications:

CPU connection	SPI channel 0
Size min	8 MByte
Size max	64 MByte
Chip select	SPI_CS0n
Bootable	Yes

Tab. 9: NOR flash specifications

3.4 NAND flash bank

On board main storage memory is a 8-bit wide NAND flash connected to the CPU's static memory controller (SMC). Optionally, it can act as boot peripheral.

The following table reports the NAND flash specifications:

CPU connection	Static memory controller
-----------------------	--------------------------

Page size	512 byte, 2 kbyte or 4 kbyte
Size min	128 MByte
Size max	2 GByte
Width	8 bit
Chip select	NAND_CS0
Bootable	Yes

Tab. 10: NAND flash specifications

3.5 Integrated FPGA

The PL is derived from Xilinx’s 7 Series FPGA technology (Artix™ -7 for the 7z010/7z020). The PL is used to extend the functionality to meet specific application requirements. The PL provides many different types of resources including configurable logic blocks (CLBs), port and width configurable block RAM (BRAM), DSP slices with 25 x 18 multiplier, 48-bit accumulator and pre-adder (DSP48E1), a user configurable analog to digital converter (XADC), clock management tiles (CMT), a configuration block with 256b AES for decryption and SHA for authentication, configurable I/Os (with differential signaling capabilities). BORA customers are able to differentiate their product in hardware by customizing their applications using PL.

3.6 Memory Map

For detailed information, please refer to section “4.1 - Address Map” of the Zynq-7000 Technical Reference Manual.

3.7 Power supply unit

BORA, as the other ULTRA Line CPU modules, embeds all the elements required for powering the unit, therefore power sequencing is self-contained and simplified. Nevertheless, power must be provided from carrier board, and therefore users should be aware of the ranges power supply can assume as well as all other parameters. For detailed information, please refer to

Section 5.1.

3.8 CPU module connectors

All interface signals BORA provides are routed through three 140 pin 0.6mm pitch stacking connectors (named J1, J2 and J3). The dedicated carrier board must mount the mating connectors and connect the desired peripheral interfaces according to BORA pinout specifications.

For mechanical information, please refer to Section 4 (Mechanical specifications). For pinout and peripherals information, please refer to Sections 6 (Pinout table) and 7 (Peripheral interfaces).

4 Mechanical specifications

This chapter describes the mechanical characteristics of the BORA module.



Mechanical drawings are available in DXF format from the BORA page on DAVE Embedded Systems website (<http://www.dave.eu/products/zynq-bora>).

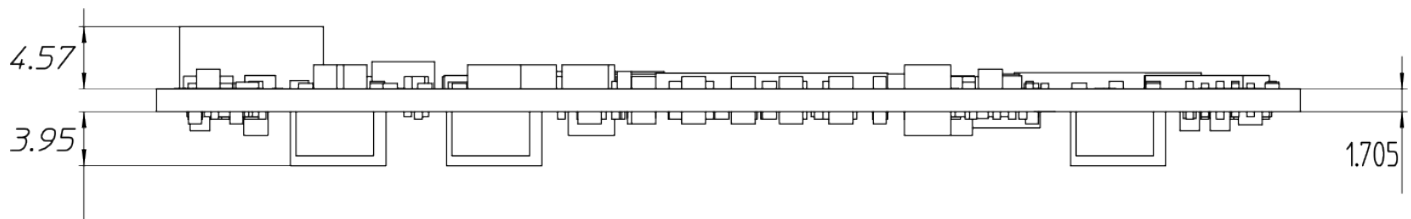

Fig. 4: Board layout - Side view

4.1 Board Layout

The following figure shows the physical dimensions of the BORA module:

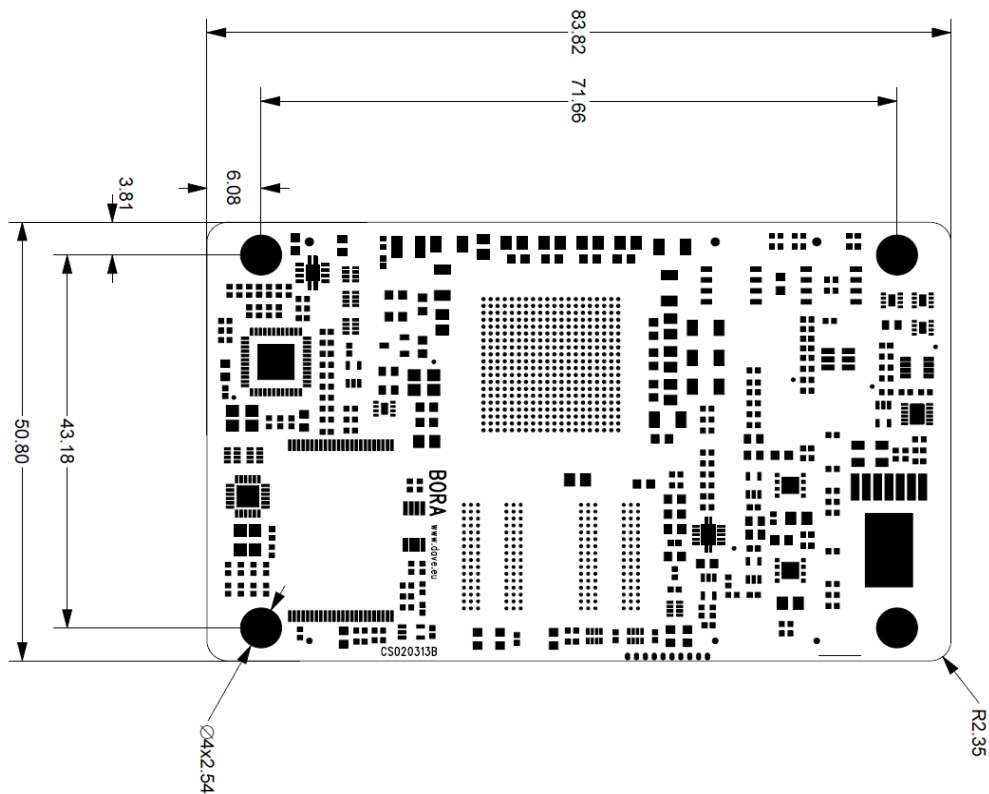

Fig. 5: Board layout - Top view

- Board height: 50.8 mm
- Board width: 83.8 mm
- Maximum components height is less than 4.6 mm.
- PCB thickness is 1.7 mm.

The following figure highlights the maximum components' heights on BORA module:

4.2 Connectors

The following figure shows the BORA connectors layout:

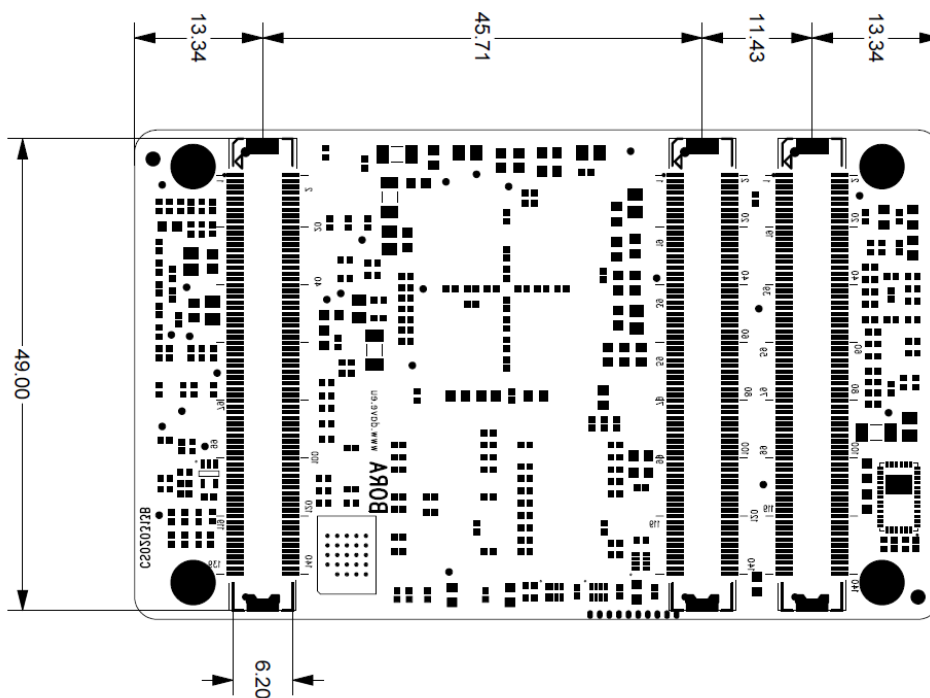

Fig. 6: Connectors layout

The following table reports connectors specifications:

Part number	Hirose FX8C-140S-SV
Height	5.1 mm
Length	48.6 mm
Depth	4.0 mm
Mating connectors	Hirose FX8C-140P-SV (5 mm board-to-board height) Hirose FX8C-140P-SV1 (6 mm board-to-board height) Hirose FX8C-140P-SV2 (7 mm board-to-board height) Hirose FX8C-140P-SV4 (9 mm board-to-board height)

Hirose FX8C-140P-SV6 (11 mm board-to-board height)

5 Power, reset and control

5.1 Power Supply Unit (PSU) and recommended power-up sequence

Implementing correct power-up sequence for Zynq-7000 processors is not a trivial task because several power rails are involved. BORA SOM simplifies this task and embeds all the needed circuitry. The following picture shows a simplified block diagram of PSU/voltage monitoring circuitry:

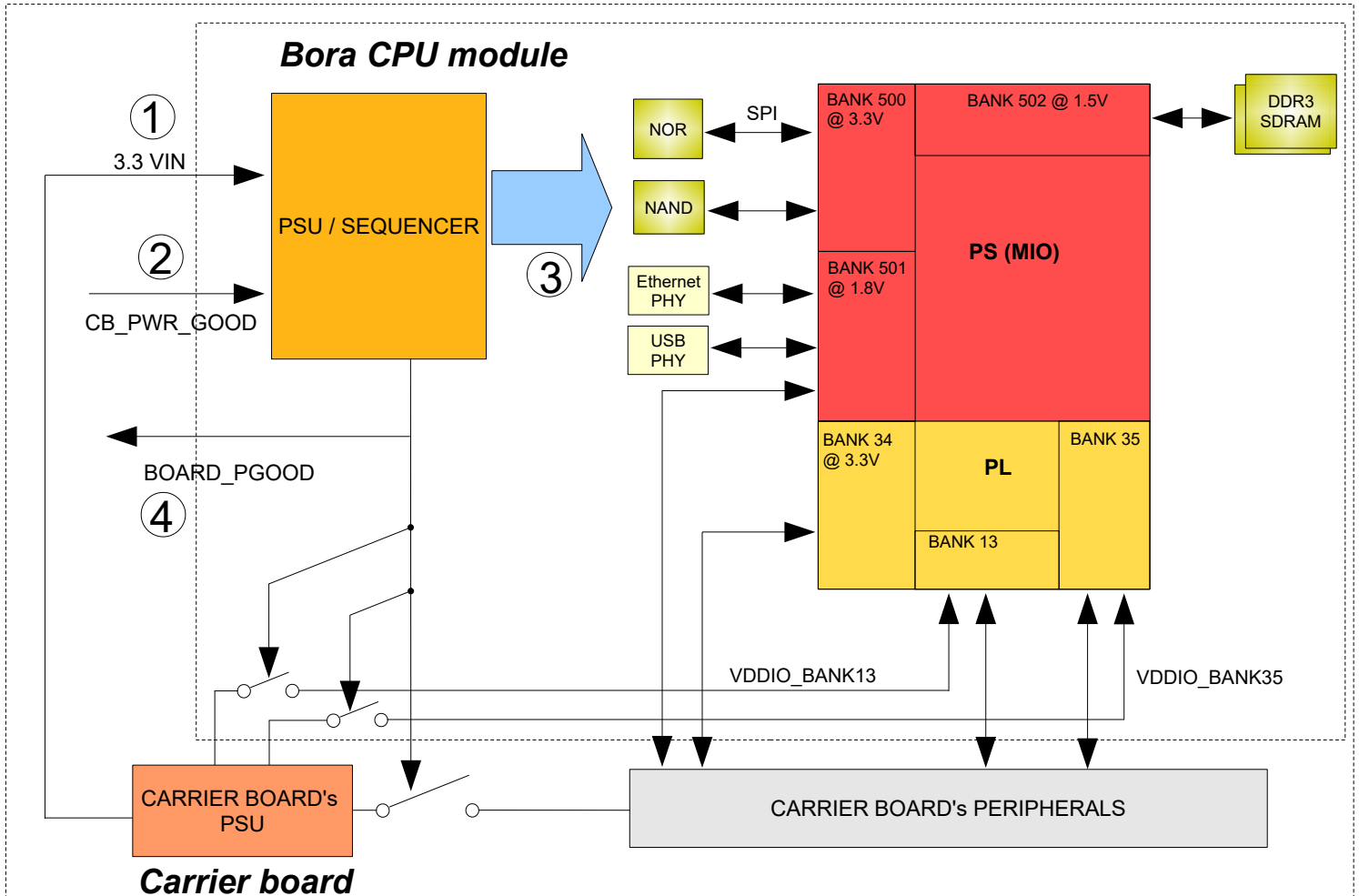

The recommended power-up sequence is:

1. main power supply rail (3.3VIN) ramps up
2. carrier board circuitry raises CB_PWR_GOOD; this indicates 3.3VIN rail is stable³
3. BORA's PSU enables and sequences DC/DC regulators to turn circuitry on
4. BOARD_PGOOD signal is raised; this active-high signal indicates that SoM's I/O is powered. This signal can be used to manage carrier board power up sequence in order to prevent back powering (from SoM to carrier board or vice versa)

Please note that FPGA Bank 13 and FPGA Bank 35 of the PL must be powered by carrier board even if they are not used to implement any function. Two dedicated power rails are available for this purpose (VDDIO_BANK35 and VDDIO_BANK13) and offers the system designer the freedom to select the I/O voltage of these two banks. The power rails of both banks are enabled by the BOARD_PGOOD signal and are connected to the I/O power supply rail provided by the carrier board. Bora's PSU is designed to be robust against misbehaving power rails. However, the recommended power-on ramp for core and I/O supplies ranges from 1 to 6 V/ms.

N.B.: Regarding power off, it is recommended that I/O supply is turned off before core supply.

5.1.1 XCIN15034 and power-off sequence

On 29th September 2015 Xilinx released a Product Change Notice indicating new power on/off requirements about Zynq components. A specific analysis has been undertaken with the help of Xilinx technical support to verify the compliance of BORA with respect to the new requirements. This activity has led to the following recommendation: in order to prevent situations that might not fulfill such requirements, 3.3VIN off ramp speed must not exceed 50 V/ms. For more details on this topic, please refer to AR #65240

³ This step is not mandatory and CB_PWR_GOOD can be left floating. CB_PWR_GOOD is provided to prevent, if necessary, BORA's PSU to turn on during ramp of carrier board 3.3VIN rail. Depending on carrier board's PSU design, this may lead to undesired glitches during ramp-up.

(<http://www.xilinx.com/support/answers/65240.html>) and XCN15034 (http://www.xilinx.com/support/documentation/customer_notices/xcn15034.pdf).

5.2 Reset

The following picture shows the simplified block diagram of reset scheme and voltage monitoring.

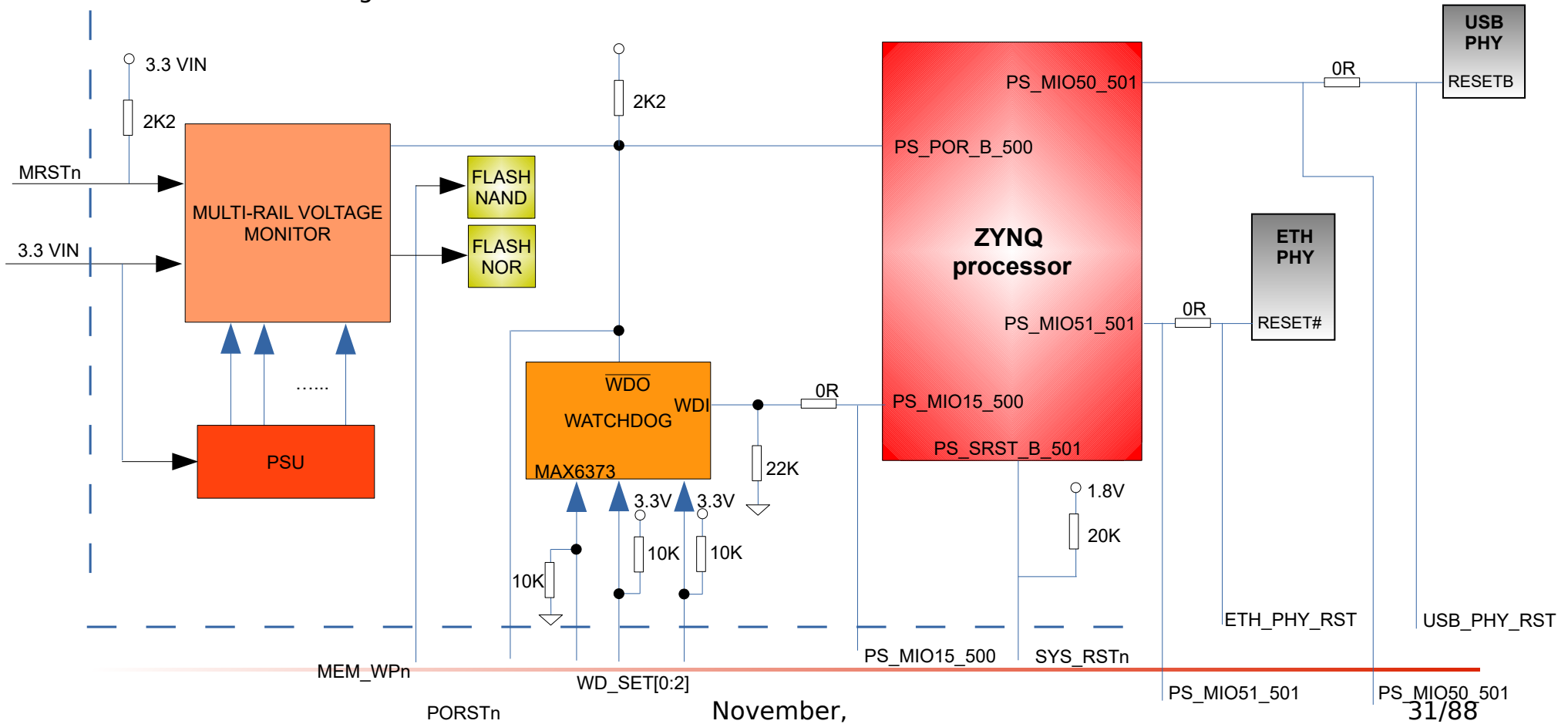

November,
2020

The available reset signals are described in detail in the following sections.

5.2.1 MRST (J2.116)

MRSTn is a de-bounced input for manual reset (for example to connect a push-button). This signal connected to the voltage monitor and is pulled-up to 3.3VIN through a 2.2kOhm resistor.

5.2.2 PORSTn (J2.114)

This is a bi-directional open-drain signal that is connected to Zynq's PS_SRST_B and can be asserted by the following devices:

- a multi-rail voltage monitor that monitors 3.3VIN power rails and all of the rails generated by BORA's PSU. This monitor:
 - in case of a power glitch, asserts MEM_WPn signal in order to prevent any spurious write operation on flash memories too. MEM_WPn is 3.3V, push-pull, active low
 - has a timeout (set through an on-board capacitor) of about 200 ms
 - provides MRSTn de-bounced input for manual reset (for example to connect a push-button). This signal is pulled-up to 3.3VIN through a 2.2kOhm resistor
- a watchdog timer (Maxim MAX6373). For more details please refer to section 5.9 (Watchdog)

PORSTn is pulled-up to 3.3VIN through a 2.2kOhm resistor.

5.2.3 SYS_RSTn (J2.112)

This signal is connected to Zynq's PS_SRST_B and is pulled-up to 1.8V through a 20kOhm resistor.

5.2.4 PS_MIO51_501 (J2.106)

By default, this signal is connected to on-board ETH PHY reset input. This allows complete software control of PHY reset sequence, even if FPGA is not programmed. In case this signals

must be used to implement different functions on carrier board, alternative routing schemes are available on request in order to free this signal. For more details please refer to department sales.

5.2.5 PS_MIO50_501 (J2.104)

By default, this signal is connected to on-board USB PHY reset input. This allows complete software control of PHY reset sequence, even if FPGA is not programmed. In case this signals must be used to implement different functions on carrier board, alternative routing schemes are available on request in order to free this signal. For more details please refer to department sales.

5.3 Voltage monitor

The voltage monitor is a Linear Technology LTC2930 (Configurable Six Supply Monitor with Adjustable Reset Timer, Manual Reset).

5.4 System boot

The boot process is multi-stage and minimally includes the Boot ROM and the first-stage boot loader (FSBL). The Zynq-7000 AP SoC includes a factory-programmed Boot ROM that is not user-accessible. The boot ROM:

- determines whether the boot is secure or non-secure
- performs some initialization of the system and clean-ups
- reads the mode pins to determine the primary boot device
- once it is satisfied, it executes the FSBL

After a system reset, the system automatically sequences to initialize the system and process the first stage boot loader from the selected external boot device. The process enables the user to configure the AP SoC platform as needed, including the PS and the PL. Optionally, the JTAG interface can be enabled to give the design engineer access to the PS and the PL for test and

debug purposes.

5.4.1 Boot modes

The boot ROM supports configuration from four different slave interfaces:

- Quad-SPI
- NAND
- NOR flash (not available on BORA)
- SD card

Boot mode is selectable via five mode pins (BOOT_MODE[4:0]), and two voltage mode signals, (VMODE[1:0]).

The BOOT_MODE pins are MIO[6:2] and the VMODE pins are MIO[8:7]. The pins are used as follows:

Function	Boot signals	Available options
JTAG mode	BOOT_MODE[3] MIO[2]	0: Cascaded JTAG 1: Independent JTAG
Boot mode	BOOT_MODE[0-2-1] MIO[5:3]	000: JTAG 010: NAND 100: Quad-SPI 110: SD card
PLLs enable	BOOT_MODE[4] MIO[6]	0: PLL used 1: PLL bypassed
MIO Bank 0 Voltage	VMODE[0] MIO[7]	0: 2.5 V, 3.3 V 1: 1.8 V
MIO Bank 0 Voltage	VMODE[1] MIO[8]	0: 2.5 V, 3.3 V 1: 1.8 V

In order to fully understand how boot works on BORA platform, please refer to chapter 6 ("Boot and configuration") of the Zynq-7000 Technical Reference Manual.

5.4.2 Default boot configuration

Default configuration for BORA module is:

- Mode[0..3] = 1000: Quad-SPI mode
- Mode[4] = 0: PLL not bypassed
- VCFG[0] = 0: 2.5V, 3.3V operations for bank 0
- VCFG[1] = 1: 1.8 operations for bank 1

Assuming that:

- default configuration is not changed,
- there's a valid boot code programmed in SPI flash memory

the actual boot sequence performed by ARM core will be:

5. Bootrom is executed from internal ROM code memory
6. FSBL is copied from on-board NOR flash memory connected to SPI0 port to on-chip SRAM by bootrom
7. FSBL is executed from on-chip SRAM
8. U-Boot bootloader (2nd stage) is copied by FSBL from NOR flash memory connected to Quad-SPI port to SDRAM
9. U-boot (2nd stage) is executed from SDRAM

If no boot code is available in SPI NOR flash, the bootrom tries JTAG peripheral booting.

5.4.3 Boot sequence customization

BOOT_MODE[4:0] are routed to the J1 connector, enabling for the customization of the boot sequence through a simple resistor network that can be implemented on carrier board hosting BORA module.

Mode signal	J1 pin	Pin name
BOOT_MODE[4]	J1.129	SPI0_SCLK/MODE4/NAND_IO1
BOOT_MODE[3]	J1.125	SPI0_DQ0/MODE3/NAND_ALE

Mode signal	J1 pin	Pin name
BOOT_MODE[2]	J1.121	SPI0_DQ2/MODE2/NAND_IO2
BOOT_MODE[1]	J1.123	SPI0_DQ1/MODE1/NAND_WE
BOOT_MODE[0]	J1.119	SPI0_DQ3/MODE0/NAND_IO0

For each BOOT_MODE[4:0] pin it is possible to populate upper or lower side resistor in order to change default value that is set on module itself.

5.5 Clock scheme

Bora is equipped with three independent active oscillators:

- processor (33.3 MHz)
- ethernet PHY (25 MHz)
- USB PHY (26 MHz)

Generally speaking, no clocks have to be provided by carrier board.

5.6 Recovery

For different reason, starting from image corruption due power loss during upgrade or unrecoverable bug while developing a new U-Boot feature, the user will need, sooner or later, to recover (*bare-metal* restore) the BORA SOM without using the bootloader itself. The following paragraphs introduce the available options. For further information, please refer to **DAVE Embedded Systems** Developers Wiki or contact the Technical Support Team.

5.6.1 JTAG Recovery

JTAG recovery, though very useful (especially in development or production environment), requires dedicated hardware and software tools. BORA provides the JTAG interface, which, besides the debug purpose, can be used for programming and recovery operations. For further information on how to use the JTAG interface, please contact the Technical Support Team.

5.6.2 SD/MMC Recovery

SD/MMC recovery is a valuable options that requires no special hardware at all, apart a properly formatted SD/MMC. The boot sequence must include the SD/MMC option and a way to enable it. When SD/MMC boot option is selected, bootrom looks for a valid FSBL on SD/MMC, which in turn will load the 2nd stage bootloader. Once the board is running after booting from SD, reprogramming the flash memory is straightforward.

5.7 Multiplexing

The PS I/O peripherals, including the static/flash memory interfaces share a multiplexed I/O (MIO) of up to 54 MIO pins. Zynq-7000 AP SoC devices also include the capability to use the I/Os that are part of the PL domain for many of the PS I/O Peripherals. This is done through an extended multiplexed I/O interface (EMIO) and is useful to gain access to more device pins (PL pins) and to allow an I/O peripheral controller to interface to user logic in the PL.

The MIO is fundamental to the I/O peripheral connections due to the limited number of MIO pins. Software programs the routing of the I/O signals to the MIO/EMIO pins. Normally, each pin is assigned to one function. One exception to this is the dual use boot mode strapping resistors (MIO [2:8]).

Please refer to the following sections of the Zynq-7000 TRM for further information on MIO/EMIO pin assignment:

- section 2.5.1 “I/O Peripheral (IOP) Interface Routing”
- section 2.5.3 “MIO Pin Assignment Considerations”
- section 2.5.4 “MIO-at-a-Glance Table”
- section 2.5.5 “MIO Signal Routing”

5.8 RTC

An on-board Maxim Integrated DS3232 device provides a very accurate, temperature-compensated real-time clock (RTC) resource with:

- Temperature-compensated crystal oscillator

- Date, time and calendar
- Alarm capability
- Backup power from external battery
- ± 3.5 ppm accuracy from -40°C to $+85^{\circ}\text{C}$
- 236 Bytes of Battery-Backed SRAM
- I²C Interface

Backup power is provided through the RTC_VBAT (J2.113) signal. If not used, RTC_VBAT must be externally connected to GND. For a detailed description of RTC characteristics, please refer to the DS3232 datasheet.

5.9 Watchdog

An external watchdog (Maxim MAX6373) is connected to the PORSTn signal. During normal operation, the microprocessor should repeatedly toggle the watchdog input WDI before the selected watchdog timeout period elapses to demonstrate that the system is processing code properly. If the μP does not provide a valid watchdog input transition before the timeout period expires, the supervisor asserts a watchdog (WDO) output to signal that the system is not executing the desired instructions within the expected time frame. The watchdog output pulse is used to reset the μP . The default mounting is depicted in the picture in section 5.2.

WDI is connected to Zynq's PS_MIO15_500 I/O. This signal is available on Bora connectors as PS_MIO15_500 (J1.133).

MAX6373 timeout is pin-selectable. It can be configured through the WD_SET0 (J2.100), WD_SET1 (J2.98) and WD_SET2 (J2.96) signals. By default, they are configured as follows:

- WD_SET2 = 1
- WD_SET1 = 1
- WD_SET0 = 0

This set selects the option (the exhaustive list of configurations options is described in table 1 of

<https://www.maximintegrated.com/en/products/power/superviso>

[rs-voltage-monitors-sequencers/MAX6373.html](#)):

- tDELAY = first edge
- tWD = 10s

In other words, WDT is started when the first transition on WDI input is detected. Once started, its timeout period is 10s. The first transition of WDI input should be under software control. However, despite of the presence of 22kOhm pull-down, during power-on sequence a spurious 0-to-1 transition may be observed on WDI input. The voltage swing of this transition is variable, since it depends on the internal Zynq's pull-up value of PS_MIO15_500 pad. In general, WDT may be inadvertently started at power-up, before software takes control of PS_MIO15_500 GPIO. To avoid this situation, it is recommended to add a 2.2kOhm pull-down on carrier board, connected to the PS_MIO15_500 signal.

In any case, when the watchdog is started, the software (bootloader/operating system) must take care of toggling the watchdog trigger pin (WDI) before the timeout expiration.

5.9.1 Selecting different configurations

Since WD_SETx signals are routed externally, WDT configuration can be changed by optional circuitry implemented on the carrier board. Different solutions can be implemented on the carrier board, depending on system requirements. The easiest circuit consists of additional stronger pull-up/down resistors connected to WD_SETx pins in order to overrule default configuration. As MAX6373 allows to change the configuration during operation, more complex solutions can be implemented as well.

Please note that on the BORAEBV carrier board, by default WDT is disabled via S1, S2 and S3 dip switches (WD_SET2=0, WD_SET1=1, WD_SET0=1).

It is also worth mentioning that Zynq integrates a System Watchdog Timer (SWDT) that can optionally generates a reset pulse on PS_MIO15_500 pad if this is configured as SWDT reset. In case such a configuration is of interest, on request MAX6373 may not be populated. For more details about this option, please contact our Sales Department.

5.10 Thermal IC

An on-board thermal IC (Texas Instruments TMP421) connected to the I²C0 interface can work as a local temperature sensor, providing the measurement of its internal temperature, but also as a remote temperature sensor, since it is connected to the XADC_DXP/XADC_DXN of the Zynq processor, providing the measurement of the Zynq internal temperature.

For a detailed description of the thermal IC characteristics, please refer to the TMP421 datasheet.

6 Pinout table

This chapter contains the pinout description of the BORA module, grouped in six tables (two – odd and even pins – for each connector) that report the pin mapping of the three 140-pin BORA connectors.

Each row in the pinout tables contains the following information:

Pin	Reference to the connector pin
Pin Name	Pin (signal) name on the BORA connectors
Internal Connections	Connections to the BORA components: CPU.<x> : pin connected to CPU (PS, processing system) pad named <x> FPGA.<x>: pin connected to FPGA (PL, programmable logic) pad named <x> CAN.<x> : pin connected to the CAN transceiver PMIC.<x> : pin connected to the Power Manager IC LAN.<x> : pin connected to the LAN PHY USB.<x> : pin connected to the USB transceiver SV.<x>: pin connected to voltage supervisor MTR: pin connected to voltage monitors
Ball/pin #	Component ball/pin number connected to signal
Supply Group	Power Supply Group
Type	Pin type: I = Input, O = Output, D= Differential, Z = High impedance, S = Supply voltage, G = Ground, A = Analog signal
Voltage	I/O voltage

6.1 Carrier board mating connector J1

J1 - ODD [1 - 139]							
Pin	Pin Name	Internal Connections	Ball/ pin #	Supply Group	Type	Voltage	Note
J1.1	DGND	DGND	-		-		
J1.3	IO L7P T1 AD2P 35	FPGA.IO L7P T1 AD2P 35	M19	BANK35	I/O		
J1.5	IO L10P T1 AD11P 35	FPGA.IO L10P T1 AD11P 35	K19	BANK35	I/O		
J1.7	IO L11P T1 SRCC 35	FPGA.IO L11P T1 SRCC 35	L16	BANK35	I/O		
J1.9	IO L8N T1 AD10N 35	FPGA.IO L8N T1 AD10N 35	M18	BANK35	I/O		
J1.11	IO L7N T1 AD2N 35	FPGA.IO L7N T1 AD2N 35	M20	BANK35	I/O		
J1.13	DGND	DGND	-		-		
J1.15	IO L9P T1 DQS AD3P 35	FPGA.IO L9P T1 DQS AD3P 35	L19	BANK35	I/O		
J1.17	IO L9N T1 DQS AD3N 35	FPGA.IO L9N T1 DQS AD3N 35	L20	BANK35	I/O		
J1.19	DGND	DGND	-		-		
J1.21	IO L20P T3 AD6P 35	FPGA.IO L20P T3 AD6P 35	K14	BANK35	I/O		
J1.23	IO L20N T3 AD6N 35	FPGA.IO L20N T3 AD6N 35	J14	BANK35	I/O		
J1.25	IO L22P T3 AD7P 35	FPGA.IO L22P T3 AD7P 35	L14	BANK35	I/O		
J1.27	IO L12N T1 MRCC 35	FPGA.IO L12N T1 MRCC 35	K18	BANK35	I/O		
J1.29	DGND	DGND	-		-		
J1.31	IO L21P T3 DQS AD14P 35	FPGA.IO L21P T3 DQS AD14P 35	N15	BANK35	I/O		
J1.33	IO L21N T3 DQS AD14N 35	FPGA.IO L21N T3 DQS AD14N 35	N16	BANK35	I/O		
J1.35	DGND	DGND	-		-		
J1.37	IO L17N T2 AD5N 35	FPGA.IO L17N T2 AD5N 35	H20	BANK35	I/O		
J1.39	IO L13N T2 MRCC 35	FPGA.IO L13N T2 MRCC 35	H17	BANK35	I/O		
J1.41	IO L19P T3 35	FPGA.IO L19P T3 35	H15	BANK35	I/O		
J1.43	IO L18P T2 AD13P 35	FPGA.IO L18P T2 AD13P 35	G19	BANK35	I/O		
J1.45	IO L16P T2 35	FPGA.IO L16P T2 35	G17	BANK35	I/O		
J1.47	IO L15N T2 DQS AD12N 35	FPGA.IO L15N T2 DQS AD12N 35	F20	BANK35	I/O		
J1.49	DGND	DGND	-		-		
J1.51	IO L2N T0 AD8N 35	FPGA.IO L2N T0 AD8N 35	A20	BANK35	I/O		
J1.53	IO L1N T0 AD0N 35	FPGA.IO L1N T0 AD0N 35	B20	BANK35	I/O		
J1.55	IO L5N T0 AD9N 35	FPGA.IO L5N T0 AD9N 35	E19	BANK35	I/O		
J1.57	IO L5P T0 AD9P 35	FPGA.IO L5P T0 AD9P 35	E18	BANK35	I/O		
J1.59	DGND	DGND	-		-		

J1 - ODD [1 - 139]							
Pin	Pin Name	Internal Connections	Ball/ pin #	Supply Group	Type	Voltage	Note
J1.61	IO_L3P_T0_DQS_AD1P_35	FPGA.IO_L3P_T0_DQS_AD1P_35	E17	BANK35	I/O		
J1.63	IO_L3N_T0_DQS_AD1N_35	FPGA.IO_L3N_T0_DQS_AD1N_35	D18	BANK35	I/O		
J1.65	DGND	DGND	-		-		
J1.67	VDDIO_BANK35	FPGA.VCCO_35	C19 F18 H14 J17 K20 M16	BANK35	VCCO	U.D.	1.8V to 3.3V User defined (U.D.)
J1.69	XADC_AGND	FPGA.GNDADC_0	J10		-		
J1.71	XADC_AGND	FPGA.GNDADC_0	J10		-		
J1.73	PS_SD0_DAT3	CPU.PS_MIO45_501	B15	BANK501	I/O	1.8V	
J1.75	PS_SD0_DAT2	CPU.PS_MIO44_501	F13	BANK501	I/O	1.8V	
J1.77	PS_SD0_DAT1	CPU.PS_MIO43_501	A9	BANK501	I/O	1.8V	
J1.79	PS_SD0_DAT0	CPU.PS_MIO42_501	E12	BANK501	I/O	1.8V	
J1.81	PS_SD0_CMD	CPU.PS_MIO41_501	C17	BANK501	I/O	1.8V	
J1.83	DGND	DGND	-		-		
J1.85	PS_SD0_CLOCK	CPU.PS_MIO40_501	D14	BANK501	I/O	1.8V	
J1.87	ETH_MDIO	CPU.PS_MIO53_501 LAN.MDIO	C11 37	BANK501	I/O	1.8V	
J1.89	ETH_MDC	CPU.PS_MIO12_501 LAN.MDC	C10 36	BANK501		1.8V	
J1.91	ETH_LED1	LAN.LED1 / PME_N1	17				
J1.93	ETH_LED2	LAN.LED2	15				
J1.95	DGND	DGND	-		-		
J1.97	ETH_TXRX1_M	LAN.TXRXM_B	6				
J1.99	ETH_TXRX1_P	LAN.TXRX_P_B	5				
J1.101	DGND	DGND	-				
J1.103	ETH_TXRX0_M	LAN.TXRXM_A	3				
J1.105	ETH_TXRX0_P	LAN.TXRX_P_A	2				
J1.107	DVDDH	LAN.DVDDH	16 34 40			1.8V	1.8V digital VDD_I/O of Ethernet PHY
J1.109	N.C.	Not Connected	-				
J1.111	USBOTG_CPEN	USB.CPEN	7				
J1.113	OTG_VBUS	USB.OTG_VBUS	2				

J1 - ODD [1 - 139]							
Pin	Pin Name	Internal Connections	Ball/ pin #	Supply Group	Type	Voltage	Note
J1.115	OTG_ID	USB.ID	1				
J1.117	DGND	DGND	-				
J1.119	SPI0_DQ3/MODE0/NAND_IO0	CPU.PS_MIO5_500	A6	BANK500		3.3V	This signal is pulled up or down by 20kOhm resistor to select proper bootstrap configuration.
J1.121	SPI0_DQ2/MODE2/NAND_IO2	CPU.PS_MIO4_500	B7	BANK500		3.3V	This signal is pulled up or down by 20kOhm resistor to select proper bootstrap configuration.
J1.123	SPI0_DQ1/MODE1/NAND_WE	CPU.PS_MIO3_500	D6	BANK500		3.3V	This signal is pulled up or down by 20kOhm resistor to select proper bootstrap configuration.
J1.125	SPI0_DQ0/MODE3/NAND_ALE	CPU.PS_MIO2_500	B8	BANK500		3.3V	This signal is pulled up or down by 20kOhm resistor to select proper bootstrap configuration.
J1.127	DGND	DGND	-				
J1.129	SPI0_SCLK/MODE4/NAND_IO1	CPU.PS_MIO6_500	A5	BANK500		3.3V	This signal is pulled up or down by 20kOhm resistor to select proper bootstrap configuration.
J1.131	NAND_BUSY	CPU.PS_MIO14_500	C5	BANK500		3.3V	
J1.133	PS_MIO15_500	CPU.PS_MIO15_500 WDT.WDI	C8 1	BANK500 -		3.3V 3.3V	
J1.135	N.C.	Not Connected	-				
J1.137	MEM_WPN	NAND.WP NOR.WP/IO2	19 C4				
J1.139	DGND	DGND	-				

J1 - EVEN [2 - 140]							
Pin	Pin Name	Internal Connections	Ball/ pin #	Supply Group	Type	Voltage	Note
J1.2	VDDIO_BANK35	FPGA.VCCO_35	C19 F18 H14	BANK35	VCCO	U.D.	1.8V to 3.3V User defined (U.D.)

J1 - EVEN [2 - 140]							
Pin	Pin Name	Internal Connections	Ball/ pin #	Supply Group	Type	Voltage	Note
			J17 K20 M16				
J1.4	DGND	DGND	-		-		
J1.6	IO L10N T1 AD11N 35	FPGA.IO L10N T1 AD11N 35	J19	BANK35	I/O	U.D.	
J1.8	IO L12P T1 MRCC 35	FPGA.IO L12P T1 MRCC 35	K17	BANK35	I/O	U.D.	
J1.10	IO L11N T1 SRCC 35	FPGA.IO L11N T1 SRCC 35	L17	BANK35	I/O	U.D.	
J1.12	IO L8P T1 AD10P 35	FPGA.IO L8P T1 AD10P 35	M17	BANK35	I/O	U.D.	
J1.14	DGND	DGND	-				
J1.16	IO L24N T3 AD15N 35	FPGA.IO L24N T3 AD15N 35	J16	BANK35	I/O	U.D.	
J1.18	IO 25 35	FPGA.IO 25 35	J15	BANK35	I/O	U.D.	
J1.20	IO L24P T3 AD15P 35	FPGA.IO L24P T3 AD15P 35	K16	BANK35	I/O	U.D.	
J1.22	IO L23N T3 35	FPGA.IO L23N T3 35	M15	BANK35	I/O	U.D.	
J1.24	DGND	DGND	-				
J1.26	IO L22N T3 AD7N 35	FPGA.IO L22N T3 AD7N 35	L15	BANK35	I/O	U.D.	
J1.28	IO L23P T3 35	FPGA.IO L23P T3 35	M14	BANK35	I/O	U.D.	
J1.30	DGND	DGND	-				
J1.32	IO L17P T2 AD5P 35	FPGA.IO L17P T2 AD5P 35	J20	BANK35	I/O	U.D.	
J1.34	IO L14P T2 AD4P SRCC 35	FPGA.IO L14P T2 AD4P SRCC 35	J18	BANK35	I/O	U.D.	
J1.36	IO L14N T2 AD4N SRCC 35	FPGA.IO L14N T2 AD4N SRCC 35	H18	BANK35	I/O	U.D.	
J1.38	DGND	DGND	-				
J1.40	IO L13P T2 MRCC 35	FPGA.IO L13P T2 MRCC 35	H16	BANK35	I/O	U.D.	
J1.42	IO L18N T2 AD13N 35	FPGA.IO L18N T2 AD13N 35	G20	BANK35	I/O	U.D.	
J1.44	IO L16N T2 35	FPGA.IO L16N T2 35	G18	BANK35	I/O	U.D.	
J1.46	IO L15P T2 DQS AD12P 35	FPGA.IO L15P T2 DQS AD12P 35	F19	BANK35	I/O	U.D.	
J1.48	DGND	DGND	-				
J1.50	IO L1P T0 AD0P 35	FPGA.IO L1P T0 AD0P 35	C20	BANK35	I/O	U.D.	
J1.52	IO L2P T0 AD8P 35	FPGA.IO L2P T0 AD8P 35	B19	BANK35	I/O	U.D.	
J1.54	IO L4N T0 35	FPGA.IO L4N T0 35	D20	BANK35	I/O	U.D.	
J1.56	IO L4P T0 35	FPGA.IO L4P T0 35	D19	BANK35	I/O	U.D.	
J1.58	IO L6P T0 35	FPGA.IO L6P T0 35	F16	BANK35	I/O	U.D.	
J1.60	DGND	DGND	-				
J1.62	IO L6N T0 VREF 35	FPGA.IO L6N T0 VREF 35	F17	BANK35	I/O	U.D.	
J1.64	IO L19N T3 VREF 35	FPGA.IO L19N T3 VREF 35	G15	BANK35	I/O	U.D.	
J1.66	VDDIO_BANK35	FPGA.VCCO_35	C19 F18	BANK35	VCCO	U.D.	1.8V to 3.3V User defined (U.D.)

J1 - EVEN [2 - 140]							
Pin	Pin Name	Internal Connections	Ball/ pin #	Supply Group	Type	Voltage	Note
			H14 J17 K20 M16				
J1.68	VDDIO_BANK35	FPGA.VCCO_35	C19 F18 H14 J17 K20 M16	BANK35	VCCO	U.D.	1.8V to 3.3V User defined (U.D.)
J1.70	XADC_AGND	FPGA.GNDADC_0	J10				
J1.72	XADC_AGND	FPGA.GNDADC_0	J10				
J1.74	IO_0_35	FPGA.IO_0_35	G14	BANK35	I/O	U.D.	
J1.76	N.C.	Not Connected	-	BANK501	I/O	1.8V	
J1.78	N.C.	Not Connected	-	BANK501	I/O	1.8V	
J1.80	PS_UART1_RX	CPU.PS_MIO49_501	C12	BANK501	I/O	1.8V	
J1.82	PS_UART1_TX	CPU.PS_MIO48_501	B12	BANK501	I/O	1.8V	
J1.84	PS_I2C0_DAT	CPU.PS_MIO47_501	B14	BANK501	I/O	1.8V	
J1.86	DGND	DGND	-		-		
J1.88	PS_I2C0_CK	CPU.PS_MIO46_501	D16	BANK501	I/O	1.8V	
J1.90	ETH_INTN	LAN.INT_N / PME_N2	38				
J1.92	DGND	DGND	-		-		
J1.94	ETH_TXRX3_M	LAN.TXRXM_D	11				
J1.96	ETH_TXRX3_P	LAN.TXRXP_D	10				
J1.98	DGND	DGND	-				
J1.100	ETH_TXRX2_M	LAN.TXRXM_C	8				
J1.102	ETH_TXRX2_P	LAN.TXRXP_C	7				
J1.104	DGND	DGND	-		-		
J1.106	CLK125_NDO	LAN.CLK125_NDO	41				
J1.108	N.C.	Not Connected	-				
J1.110	N.C.	Not Connected	-				
J1.112	DGND	DGND	-				
J1.114	USBP1	USB.DP	6				
J1.116	USBM1	USB.DM	5				
J1.118	DGND	DGND	-		-		
J1.120	SPI0_CS0N	CPU.PS_MIO1_500	A7	BANK500		3.3V	

J1 - EVEN [2 - 140]							
Pin	Pin Name	Internal Connections	Ball/ pin #	Supply Group	Type	Voltage	Note
		NOR.CS#	C2				
J1.122	NAND_CS0/SPI0_CS1	CPU.PS_MIO0_500 NAND.CE#	E6 9	BANK500		3.3V	
J1.124	NAND_IO3	CPU.PS_MIO13_500 NAND.IO3	E8 32	BANK500	I/O	3.3V	
J1.126	NAND_IO4	CPU.PS_MIO9_500 NAND.IO4	B5 41	BANK500	I/O	3.3V	
J1.128	NAND_IO5	CPU.PS_MIO10_500 NAND.IO5	E9 42	BANK500	I/O	3.3V	
J1.130	DGND	DGND	-		-		
J1.132	NAND_IO6	CPU.PS_MIO11_500 NAND.IO6	C6 43	BANK500	I/O	3.3V	
J1.134	NAND_IO7	CPU.PS_MIO12_500 NAND.IO7	D9 44	BANK500	I/O	3.3V	
J1.136	NAND_RD_B/VCFG1	CPU.PS_MIO8_500 NAND.RE#	D5 8	BANK500		3.3V	This signal is pulled up or down by 20kOhm resistor to select proper bootstrap configuration.
J1.138	NAND_CLE/VCFG0	CPU.PS_MIO7_500 NAND.CLE#	D8 16	BANK500		3.3V	This signal is pulled up or down by 20kOhm resistor to select proper bootstrap configuration.
J1.140	DGND	DGND	-				

6.2 Carrier board mating connector J2

J2 - ODD [1-139]							
Pin	Pin Name	Internal Connections	Ball/ pin #	Supply Group	Type	Voltage	Note
J2.1	DGND	DGND	-		-		
J2.3	DGND	DGND	-		-		
J2.5	IO_L8P_T1_34	FPGA.IO_L8P_T1_34	W14	BANK34	I/O	3.3V	
J2.7	IO_L8N_T1_34	FPGA.IO_L8N_T1_34	Y14	BANK34	I/O	3.3V	

J2 - ODD [1-139]							
Pin	Pin Name	Internal Connections	Ball/ pin #	Supply Group	Type	Voltage	Note
J2.9	IO_L6P_T0_34	CAN.D FPGA.IO_L6P_T0_34	1 P14	BANK34	I/O	3.3V	
J2.11	IO_L6N_T0_VREF_34	FPGA.IO_L6N_T0_VREF_34	R14	BANK34	I/O	3.3V	
J2.13	DGND	DGND	-	-	-	-	
J2.15	IO_L3P_T0_DQS_PUDC_B_34	FPGA.IO_L3P_T0_DQS_PUDC_B_34	U13	BANK34	I/O	3.3V	Internally connected to 3V3 via 10K resistor
J2.17	IO_L3N_T0_DQS_34	FPGA.IO_L3N_T0_DQS_34	V13	BANK34	I/O	3.3V	
J2.19	IO_L2P_T0_34	FPGA.IO_L2P_T0_34	T12	BANK34	I/O	3.3V	
J2.21	IO_L2N_T0_34	FPGA.IO_L2N_T0_34	U12	BANK34	I/O	3.3V	
J2.23	DGND	DGND	-	-	-	-	
J2.25	IO_L22P_T3_34	FPGA.IO_L22P_T3_34	W18	BANK34	I/O	3.3V	
J2.27	IO_L22N_T3_34	FPGA.IO_L22N_T3_34	W19	BANK34	I/O	3.3V	
J2.29	IO_L21P_T3_DQS_34	FPGA.IO_L21P_T3_DQS_34	V17	BANK34	I/O	3.3V	
J2.31	IO_L21N_T3_DQS_34	FPGA.IO_L21N_T3_DQS_34	V18	BANK34	I/O	3.3V	
J2.33	DGND	DGND	-	-	-	-	
J2.35	IO_L19P_T3_34	CAN.R FPGA.IO_L19P_T3_34	4 R16	BANK34	I/O	3.3V	
J2.37	IO_L19N_T3_VREF_34	FPGA.IO_L19N_T3_VREF_34	R17	BANK34	I/O	3.3V	
J2.39	IO_L18P_T2_34	FPGA.IO_L18P_T2_34	V16	BANK34	I/O	3.3V	
J2.41	IO_L18N_T2_34	FPGA.IO_L18N_T2_34	W16	BANK34	I/O	3.3V	
J2.43	DGND	DGND	-	-	-	-	
J2.45	IO_L15P_T2_DQS_34	FPGA.IO_L15P_T2_DQS_34	T20	BANK34	I/O	3.3V	
J2.47	IO_L15N_T2_DQS_34	FPGA.IO_L15N_T2_DQS_34	U20	BANK34	I/O	3.3V	
J2.49	DGND	DGND	-	-	-	-	
J2.51	IO_L13P_T1_MRCC_34	FPGA.IO_L13P_T1_MRCC_34	N18	BANK34	I/O	3.3V	
J2.53	IO_L13N_T1_MRCC_34	FPGA.IO_L13N_T1_MRCC_34	P19	BANK34	I/O	3.3V	
J2.55	DGND	DGND	-	-	-	-	
J2.57	IO_L11P_T1_SRCC_34	FPGA.IO_L11P_T1_SRCC_34	U14	BANK34	I/O	3.3V	
J2.59	IO_L11N_T1_SRCC_34	FPGA.IO_L11N_T1_SRCC_34	U15	BANK34	I/O	3.3V	
J2.61	DGND	DGND	-	-	-	-	
J2.63	IO_L10P_T1_34	FPGA.IO_L10P_T1_34	V15	BANK34	I/O	3.3V	
J2.65	IO_L10N_T1_34	FPGA.IO_L10N_T1_34	W15	BANK34	I/O	3.3V	
J2.67	IO_25_34	FPGA.IO_25_34	T19	BANK34	I/O	3.3V	
J2.69	IO_0_34	FPGA.IO_0_34	R19	BANK34	I/O	3.3V	
J2.71	DGND	DGND	-	-	-	-	
J2.73	N.C.	Not Connected	-	-	-	-	

J2 - ODD [1-139]							
Pin	Pin Name	Internal Connections	Ball/ pin #	Supply Group	Type	Voltage	Note
J2.75	N.C.	Not Connected	-		-		
J2.77	N.C.	Not Connected	-		-		
J2.79	N.C.	Not Connected	-		-		
J2.81	N.C.	Not Connected	-		-		
J2.83	N.C.	Not Connected	-		-		
J2.85	N.C.	Not Connected	-		-		
J2.87	N.C.	Not Connected	-		-		
J2.89	N.C.	Not Connected	-		-		
J2.91	N.C.	Not Connected	-		-		
J2.93	RTC_32KHZ	RTC.32KHZ	1		-		
J2.95	RTC_RST	RTC.RST#	4		-		
J2.97	XADC_VN_R	FPGA.VN_0	L10		I/O		
J2.99	XADC_VP_R	FPGA.VP_0	K9		I/O		
J2.101	N.C.	Not Connected	-		-		
J2.103	CONN_SPI_RSTn	NOR.RESET#/RFU	A4		-		
J2.105	CAN_L	CAN.L	6		I/O		
J2.107	CAN_H	CAN.H	7		I/O		
J2.109	DGND	DGND	-		-		
J2.111	RTC_INT/SQW	RTC.RTC_INT/SQW	3				It can be left open if not used. When used, a proper pull-up resistor is required on the carrier board. For further details, please refer to the Maxim Integrated DS3232 datasheet.
J2.113	RTC_VBAT	RTC.VBAT	6				
J2.115	VBAT	CPU.VCCBATT_0	F11				Please refer to Zynq-7000 Technical Reference Manual
J2.117	DGND	DGND	-		-		
J2.119	3.3VIN	+3.3 V	-		-		
J2.121	3.3VIN	+3.3 V	-		-		
J2.123	3.3VIN	+3.3 V	-		-		
J2.125	DGND	DGND	-		-		
J2.127	3.3VIN	+3.3 V	-		-		
J2.129	3.3VIN	+3.3 V	-		-		
J2.131	3.3VIN	+3.3 V	-		-		
J2.133	3.3VIN	+3.3 V	-		-		
J2.135	3.3VIN	+3.3 V	-		-		

J2 - ODD [1-139]							
Pin	Pin Name	Internal Connections	Ball/ pin #	Supply Group	Type	Voltage	Note
J2.137	3.3VIN	+3.3 V	-		-		
J2.139	DGND	DGND	-		-		

J2 - EVEN [2-140]							
Pin	Pin Name	Internal Connections	Ball/ pin #	Supply Group	Type	Voltage	Note
J2.2	DGND	DGND	-		-		
J2.4	IO L9P T1 DQS 34	FPGA.IO L9P T1 DQS 34	T16	BANK34	I/O	3.3V	
J2.6	IO L9N T1 DQS 34	FPGA.IO L9N T1 DQS 34	U17	BANK34	I/O	3.3V	
J2.8	IO L7P T1 34	FPGA.IO L7P T1 34	Y16	BANK34	I/O	3.3V	
J2.10	IO L7N T1 34	FPGA.IO L7N T1 34	Y17	BANK34	I/O	3.3V	
J2.12	DGND	DGND	-		-		
J2.14	IO L5P T0 34	FPGA.IO L5P T0 34	T14	BANK34	I/O	3.3V	
J2.16	IO L5N T0 34	FPGA.IO L5N T0 34	T15	BANK34	I/O	3.3V	
J2.18	IO L4P T0 34	FPGA.IO L4P T0 34	V12	BANK34	I/O	3.3V	
J2.20	IO L4N T0 34	FPGA.IO L4N T0 34	W13	BANK34	I/O	3.3V	
J2.22	DGND	DGND	-		-		
J2.24	IO L24P T3 34	FPGA.IO L24P T3 34	P15	BANK34	I/O	3.3V	
J2.26	IO L24N T3 34	FPGA.IO L24N T3 34	P16	BANK34	I/O	3.3V	
J2.28	IO L23P T3 34	FPGA.IO L23P T3 34	N17	BANK34	I/O	3.3V	
J2.30	IO L23N T3 34	FPGA.IO L23N T3 34	P18	BANK34	I/O	3.3V	
J2.32	DGND	DGND	-		-		
J2.34	IO L20P T3 34	FPGA.IO L20P T3 34	T17	BANK34	I/O	3.3V	
J2.36	IO L20N T3 34	FPGA.IO L20N T3 34	R18	BANK34	I/O	3.3V	
J2.38	IO L1P T0 34	FPGA.IO L1P T0 34	T11	BANK34	I/O	3.3V	
J2.40	IO L1N T0 34	FPGA.IO L1N T0 34	T10	BANK34	I/O	3.3V	
J2.42	DGND	DGND	-		-		
J2.44	IO L17P T2 34	FPGA.IO L17P T2 34	Y18	BANK34	I/O	3.3V	
J2.46	IO L17N T2 34	FPGA.IO L17N T2 34	Y19	BANK34	I/O	3.3V	
J2.48	IO L16P T2 34	FPGA.IO L16P T2 34	V20	BANK34	I/O	3.3V	
J2.50	IO L16N T2 34	FPGA.IO L16N T2 34	W20	BANK34	I/O	3.3V	
J2.52	DGND	DGND	-		-		

J2 - EVEN [2-140]							
Pin	Pin Name	Internal Connections	Ball/pin #	Supply Group	Type	Voltage	Note
J2.54	IO_L14P_T2_SRCC_34	FPGA.IO_L14P_T2_SRCC_34	N20	BANK34	I/O	3.3V	
J2.56	IO_L14N_T2_SRCC_34	FPGA.IO_L14N_T2_SRCC_34	P20	BANK34	I/O	3.3V	
J2.58	DGND	DGND	-		-		
J2.60	IO_L12P_T1_MRCC_34	FPGA.IO_L12P_T1_MRCC_34	U18	BANK34	I/O	3.3V	
J2.62	IO_L12N_T1_MRCC_34	FPGA.IO_L12N_T1_MRCC_34	U19	BANK34	I/O	3.3V	
J2.64	DGND	DGND	-		-		
J2.66	N.C.	Not Connected	-		-		
J2.68	N.C.	Not Connected	-		-		
J2.70	N.C.	Not Connected	-		-		
J2.72	N.C.	Not Connected	-		-		
J2.74	N.C.	Not Connected	-		-		
J2.76	N.C.	Not Connected	-		-		
J2.78	N.C.	Not Connected	-		-		
J2.80	JTAG_TDO	CPU.TDO_0	F6				
J2.82	JTAG_TDI	CPU.TDI_0	G6				
J2.84	JTAG_TMS	CPU.TMS_0	J6				
J2.86	JTAG_TCK	CPU.TCK_0	F9				
J2.88	DGND	DGND	-				
J2.90	FPGA_INIT_B	FPGA.INIT_B_0	R10				
J2.92	FPGA_PROGRAM_B	FPGA.PROGRAM_B_0	L6				
J2.94	FPGA_DONE	FPGA.DONE_0	R11				
J2.96	WD_SET2	WDT.SET2	6				
J2.98	WD_SET1	WDT.SET1	5				
J2.100	WD_SET0	WDT.SET0	4				
J2.102	DGND	DGND	-				
J2.104	PS_MIO50_501/ USB0_PHY_RST	CPU.PS_MIO50_501 USBOTG.RESETB	B13 22				Please refer to section 5.2.5
J2.106	PS_MIO51_501/ ETH0_PHY_RST	CPU.PS_MIO51_501 ETHPHY1GB.RESET_N	B9 42				Please refer to section 5.2.4
J2.108	BOARD_PGOOD	PSUSWITCHFPGABANK13.ON PSUSWITCHFPGABANK35.ON PSUSWITCHFPGABANK500/34.ON PSUSWITCHFPGABANK501.ON DDRREFREGULATOR.PGOOD	3 3 3 3 9				Please refer to section 5.1
J2.110	CB_PWR_GOOD	1V0REGULATOR.ENABLE	-				Please refer to section 5.1
J2.112	SYS_RSTN	CPU.PS_SRST_B_501	B10				Please refer to section 5.2

J2 - EVEN [2-140]							
Pin	Pin Name	Internal Connections	Ball/pin #	Supply Group	Type	Voltage	Note
J2.114	PORSTN	CPU.PS_POR_B_500 MTR.RST#	C7 5				Please refer to section 5.2
J2.116	MRSTN	MTR.MR	6				
J2.118	DGND	DGND	-				
J2.120	3.3VIN	+3.3 V	-				
J2.122	3.3VIN	+3.3 V	-				
J2.124	DGND	DGND	-				
J2.126	3.3VIN	+3.3 V	-				
J2.128	3.3VIN	+3.3 V	-				
J2.130	3.3VIN	+3.3 V	-		-		
J2.132	3.3VIN	+3.3 V	-		-		
J2.134	3.3VIN	+3.3 V	-		-		
J2.136	3.3VIN	+3.3 V	-		-		
J2.138	3.3VIN	+3.3 V	-		-		
J2.140	DGND	DGND	-		-		

6.3 Carrier board mating connector J3

J3 - ODD [1-139]							
Pin	Pin Name	Internal Connections	Ball/pin #	Supply Group	Type	Voltage	Note
J3.1	N.C.	Not Connected	-		-		
J3.3	N.C.	Not Connected	-		-		
J3.5	N.C.	Not Connected	-		-		
J3.7	N.C.	Not Connected	-		-		
J3.9	N.C.	Not Connected	-		-		
J3.11	N.C.	Not Connected	-		-		
J3.13	N.C.	Not Connected	-		-		
J3.15	N.C.	Not Connected	-		-		
J3.17	N.C.	Not Connected	-		-		
J3.19	N.C.	Not Connected	-		-		

J3 - ODD [1-139]							
Pin	Pin Name	Internal Connections	Ball/ pin #	Supply Group	Type	Voltage	Note
J3.21	N.C.	Not Connected	-		-		
J3.23	N.C.	Not Connected	-		-		
J3.25	N.C.	Not Connected	-		-		
J3.27	N.C.	Not Connected	-		-		
J3.29	N.C.	Not Connected	-		-		
J3.31	N.C.	Not Connected	-		-		
J3.33	N.C.	Not Connected	-		-		
J3.35	N.C.	Not Connected	-		-		
J3.37	N.C.	Not Connected	-		-		
J3.39	N.C.	Not Connected	-		-		
J3.41	N.C.	Not Connected	-		-		
J3.43	N.C.	Not Connected	-		-		
J3.45	N.C.	Not Connected	-		-		
J3.47	N.C.	Not Connected	-		-		
J3.49	N.C.	Not Connected	-		-		
J3.51	N.C.	Not Connected	-		-		
J3.53	N.C.	Not Connected	-		-		
J3.55	N.C.	Not Connected	-		-		
J3.57	N.C.	Not Connected	-		-		
J3.59	N.C.	Not Connected	-		-		
J3.61	N.C.	Not Connected	-		-		
J3.63	N.C.	Not Connected	-		-		
J3.65	N.C.	Not Connected	-		-		
J3.67	DGND	DGND	-		-		
J3.69	N.C.	Not Connected	-		-		
J3.71	N.C.	Not Connected	-		-		
J3.73	N.C.	Not Connected	-		-		
J3.75	N.C.	Not Connected	-		-		
J3.77	N.C.	Not Connected	-		-		
J3.79	N.C.	Not Connected	-		-		
J3.81	N.C.	Not Connected	-		-		
J3.83	N.C.	Not Connected	-		-		
J3.85	N.C.	Not Connected	-		-		
J3.87	N.C.	Not Connected	-		-		
J3.89	N.C.	Not Connected	-		-		
J3.91	N.C.	Not Connected	-		-		

J3 - ODD [1-139]							
Pin	Pin Name	Internal Connections	Ball/ pin #	Supply Group	Type	Voltage	Note
J3.93	DGND	DGND	-		-		
J3.95	VDDIO_BANK13	FPGA.VCCO_13	T8 U11 W7 Y10	BANK13	VCCO	U.D.	N.B. Although BANK 13 is not available on Bora SOMs equipped with the XC7Z010 SOC, VDDIO_BANK13 pin must not be left open and must be connected as described in Section 7.3.3.
J3.97	VDDIO_BANK13	FPGA.VCCO_13	T8 U11 W7 Y10	BANK13	VCCO	U.D.	
J3.99	VDDIO_BANK13	FPGA.VCCO_13	T8 U11 W7 Y10	BANK13	VCCO	U.D.	
J3.101	DGND	DGND	-		-		
J3.103	DGND	DGND	-		-		
J3.105	IO L21P T3 DQS_13	FPGA.IO L21P T3 DQS_13	V11	BANK13	I/O	U.D.	
J3.107	IO L21N T3 DQS_13	FPGA.IO L21N T3 DQS_13	V10	BANK13	I/O	U.D.	
J3.109	DGND	DGND	-		-		
J3.111	IO L19P T3_13	FPGA.IO L19P T3_13	T5	BANK13	I/O	U.D.	
J3.113	IO L19N T3 VREF_13	FPGA.IO L19N T3 VREF_13	U5	BANK13	I/O	U.D.	
J3.115	DGND	DGND	-		-		
J3.117	IO L18P T2_13	FPGA.IO L18P T2_13	W11	BANK13	I/O	U.D.	
J3.119	IO L18N T2_13	FPGA.IO L18N T2_13	Y11	BANK13	I/O	U.D.	
J3.121	DGND	DGND	-		-		
J3.123	IO L16P T2_13	FPGA.IO L16P T2_13	W10	BANK13	I/O	U.D.	
J3.125	IO L16N T2_13	FPGA.IO L16N T2_13	W9	BANK13	I/O	U.D.	
J3.127	DGND	DGND	-		-		
J3.129	IO L14P T2_SRCC_13	FPGA.IO L14P T2_SRCC_13	Y9	BANK13	I/O	U.D.	
J3.131	IO L14N T2_SRCC_13	FPGA.IO L14N T2_SRCC_13	Y8	BANK13	I/O	U.D.	
J3.133	DGND	DGND	-		-		
J3.135	IO L12P T1_MRCC_13	FPGA.IO L12P T1_MRCC_13	T9	BANK13	I/O	U.D.	
J3.137	IO L12N T1_MRCC_13	FPGA.IO L12N T1_MRCC_13	U10	BANK13	I/O	U.D.	
J3.139	DGND	DGND	-		-		

J3 - EVEN [2-140]							
Pin	Pin Name	Internal Connections	Ball/pin #	Supply Group	Type	Voltage	Note
J3.2	N.C.	Not Connected	-		-		
J3.4	N.C.	Not Connected	-		-		
J3.6	N.C.	Not Connected	-		-		
J3.8	N.C.	Not Connected	-		-		
J3.10	N.C.	Not Connected	-		-		
J3.12	N.C.	Not Connected	-		-		
J3.14	N.C.	Not Connected	-		-		
J3.16	N.C.	Not Connected	-		-		
J3.18	N.C.	Not Connected	-		-		
J3.20	N.C.	Not Connected	-		-		
J3.22	N.C.	Not Connected	-		-		
J3.24	N.C.	Not Connected	-		-		
J3.26	N.C.	Not Connected	-		-		
J3.28	N.C.	Not Connected	-		-		
J3.30	N.C.	Not Connected	-		-		
J3.32	N.C.	Not Connected	-		-		
J3.34	N.C.	Not Connected	-		-		
J3.36	N.C.	Not Connected	-		-		
J3.38	N.C.	Not Connected	-		-		
J3.40	N.C.	Not Connected	-		-		
J3.42	N.C.	Not Connected	-		-		
J3.44	N.C.	Not Connected	-		-		
J3.46	N.C.	Not Connected	-		-		
J3.48	N.C.	Not Connected	-		-		
J3.50	N.C.	Not Connected	-		-		
J3.52	N.C.	Not Connected	-		-		
J3.54	N.C.	Not Connected	-		-		
J3.56	N.C.	Not Connected	-		-		
J3.58	N.C.	Not Connected	-		-		
J3.60	N.C.	Not Connected	-		-		
J3.62	N.C.	Not Connected	-		-		
J3.64	N.C.	Not Connected	-		-		
J3.66	N.C.	Not Connected	-		-		
J3.68	DGND	DGND	-		-		
J3.70	N.C.	Not Connected	-		-		
J3.72	MON_VCCPLL	-	-				By default this pins must not be

J3 - EVEN [2-140]							
Pin	Pin Name	Internal Connections	Ball/pin #	Supply Group	Type	Voltage	Note
J3.74	MON_XADC_VCC	-	-				connected. Optionally they can route power voltage generated by BORA PSU. This routing option is meant to enable monitoring of such voltages by the carrier board circuitry. These signals are not meant to power carrier board devices. For more information please contact technical support.
J3.76	MON_FPGA_VDDIO_BANK35	-	-				
J3.78	MON_FPGA_VDDIO_BANK34	-	-				
J3.80	MON_FPGA_VDDIO_BANK13	-	-				
J3.82	MON_1.8V_IO	-	-				
J3.84	MON_3.3V	-	-				
J3.86	MON_1V2_ETH	-	-				
J3.88	MON_VDDQ_1V5	-	-				
J3.90	MON_1.8V	-	-				
J3.92	MON_1.0V	-	-				
J3.94	DGND	DGND	-				
J3.96	VDDIO_BANK13	FPGA.VCCO_13	T8 U11 W7 Y10	BANK13	VCCO	U.D.	N.B. Although BANK 13 is not available on Bora SOMs equipped with the XC7Z010 SOC, VDDIO_BANK13 pin must not be left open and must be connected as described in Section 7.3.3.
J3.98	VDDIO_BANK13	FPGA.VCCO_13	T8 U11 W7 Y10	BANK13	VCCO	U.D.	
J3.100	IO_L6N_T0_VREF_13	FPGA.IO_L6N_T0_VREF_13	V5	BANK13	I/O	U.D.	
J3.102	DGND	DGND	-				
J3.104	IO_L22P_T3_13	FPGA.IO_L22P_T3_13	V6	BANK13	I/O	U.D.	
J3.106	IO_L22N_T3_13	FPGA.IO_L22N_T3_13	W6	BANK13	I/O	U.D.	
J3.108	DGND	DGND	-				
J3.110	IO_L20P_T3_13	FPGA.IO_L20P_T3_13	Y12	BANK13	I/O	U.D.	
J3.112	IO_L20N_T3_13	FPGA.IO_L20N_T3_13	Y13	BANK13	I/O	U.D.	
J3.114	DGND	DGND	-				
J3.116	IO_L17P_T2_13	FPGA.IO_L17P_T2_13	U9	BANK13	I/O	U.D.	
J3.118	IO_L17N_T2_13	FPGA.IO_L17N_T2_13	U8	BANK13	I/O	U.D.	
J3.120	DGND	DGND	-				
J3.122	IO_L15P_T2_DQS_13	FPGA.IO_L15P_T2_DQS_13	V8	BANK13	I/O	U.D.	
J3.124	IO_L15N_T2_DQS_13	FPGA.IO_L15N_T2_DQS_13	W8	BANK13	I/O	U.D.	
J3.126	DGND	DGND	-				
J3.128	IO_L13P_T2_MRCC_13	FPGA.IO_L13P_T2_MRCC_13	Y7	BANK13	I/O	U.D.	
J3.130	IO_L13N_T2_MRCC_13	FPGA.IO_L13N_T2_MRCC_13	Y6	BANK13	I/O	U.D.	
J3.132	DGND	DGND	-				

J3 - EVEN [2-140]							
Pin	Pin Name	Internal Connections	Ball/pin #	Supply Group	Type	Voltage	Note
J3.134	IO_L11P_T1_SRCC_13	FPGA.IO_L11P_T1_SRCC_13	U7	BANK13	I/O	U.D.	
J3.136	IO_L11N_T1_SRCC_13	FPGA.IO_L11N_T1_SRCC_13	V7	BANK13	I/O	U.D.	
J3.138	DGND	DGND	-		-		
J3.140	DGND	DGND	-		-		

7 Peripheral interfaces

BORA modules implement a number of peripheral interfaces through the J1, J2 and J3 connectors. The following notes apply to those interfaces:

- Some interfaces/signals are available only with/without certain configuration options of the BORA module. Each signal's availability is noted in the "Notes" column on the table of each interface.
- The peripherals described in the following sections represent the default configuration for the BORA SOM, which match with the features provided by the electronics implemented on the module. As an example, the Zynq device provides two USB 2.0 controllers, but the BORA SOM provides one USB OTG port, with transceiver connected to one of the controllers and signals routed to the module connectors. Therefore, only one USB port will be described in details.

The signals for each interface are described in the related tables. The following notes summarize the column headers for these tables:

- "Pin name" - The symbolic name of each signal
- "Conn. Pin" - The pin number on the module connectors
- "Function" - Signal description
- "Notes" - This column summarizes configuration requirements and recommendations for each signal.

7.1 Notes on pin assignment

For further information, please refer to section 5.7 "Multiplexing". For detailed information on MIO and EMIO configuration, please refer to section 2.5.1 ("I/O Peripheral (IOP) Interface Routing") of the Zynq-7000 Technical Reference Manual.

On the BORA SOM, the MIO module is configured for providing a standard set of peripherals (eg, Ethernet, USB, ...); some pins of the EMIO are also used to implement some functions (eg: I2C,

specific I/Os). Please refer to the following sections for detailed information.

7.2 PS interfaces

The 54 pins of the MIO module are assigned as reported in the following table:

MIO pins	Function
MIO[0:14]	Quad-SPI and NAND flash
MIO[15]	EX_WDT_REARM (watchdog WDI) Optionally, it can act as SWDT reset out
MIO[16:27]	Gigabit Ethernet
MIO[28:39]	USB On-The-Go
MIO[40:45]	SD/SDIO/MMC
MIO[46:47]	I ² C0
MIO[48:49]	UART1
MIO[52]	Ethernet Management Data Clock input
MIO[53]	Ethernet Management Data Input/Output

7.2.1 Gigabit Ethernet

On-board Ethernet PHY (Micrel KSZ9031RNX) provides interface signals required to implement the 10/100/1000 Mbps Ethernet port. The transceiver is connected to the Gigabit Ethernet Controller (GEM) through RGMII interface on MIO bank 1, pins PS_MIO[16:27]. For further details (eg: connection and selection of the magnetics), please refer to the Micrel KSZ9031RNX datasheet.

The following table describes the interface signals:

Pin name	Conn. Pin	Function	Notes
ETH_TXRX0_P	J1.105	Media Dependent Interface[0], positive pin	
ETH_TXRX0_M	J1.103	Media Dependent Interface[0], negative pin	
ETH_TXRX1_P	J1.99	Media Dependent Interface[1], positive pin	

Pin name	Conn. Pin	Function	Notes
ETH_TXRX1_M	J1.97	Media Dependent Interface[1], negative pin	
ETH_TXRX2_P	J1.102	Media Dependent Interface[2], positive pin	
ETH_TXRX2_M	J1.100	Media Dependent Interface[2], negative pin	
ETH_TXRX3_P	J1.96	Media Dependent Interface[3], positive pin	
ETH_TXRX3_M	J1.94	Media Dependent Interface[3], negative pin	
ETH_MDIO	J1.87	Management Data Input/Output	
ETH_MDC	J1.89	Management Data Clock input	
ETH_INTn	J1.90	Interrupt output	
ETH_LED1	J1.91	Activity LED	
ETH_LED2	J1.93	Link LED	
DVDDH	J1.107	1.8V digital VDD_I/O of Ethernet PHY	

7.2.2 USB

BORA provides one USB 2.0 (Full Speed, up to 480 Mbps) port with on-board PHY (SMSC USB3317) and support to the On-The-Go (OTG) specifications. The transceiver is connected to the USB1 controller (MIO bank 1, pins PS_MIO[28:39]).

The following table describes the interface signals:

Pin name	Conn. Pin	Function	Notes
USBP1	J1.114	D+ pin of the USB cable	
USBM1	J1.116	D- pin of the USB cable	
USBOTG_CPEN	J1.111	External 5 volt supply enable.	This pin is used to enable the external Vbus power supply.
OTG_VBUS	J1.113	VBUS pin of the USB	

Pin name	Conn. Pin	Function	Notes
		cable	
OTG_ID	J1.115	ID pin of the USB cable	For non-OTG applications this pin can be floated. For an A-device ID is grounded. For a B-device ID is floated.

7.2.3 Quad-SPI

Quad-SPI is used to access multi-bit serial flash memory devices for high throughput and low pin count applications. The controller operates in one of three modes: I/O mode, linear addressing mode, and legacy SPI mode.

The following table describes the interface signals:

Pin name	Conn. Pin	Function	Notes
SPI0_CS0	J1.120	Chip select 0	MIO bank 0, pin 1
SPI0_CS1	J1.122	Chip select 1	MIO bank 0, pin 0
SPI0_DQ0	J1.125	1-bit: Master Output 2-bit: I/O0 4-bit: I/O0	MIO bank 0, pin 2
SPI0_DQ1	J1.123	1-bit: Master Input 2-bit: I/O1 4-bit: I/O1	MIO bank 0, pin 3
SPI0_DQ2	J1.121	1-bit: Write protect 2-bit: Write protect 4-bit: I/O0	MIO bank 0, pin 4
SPI0_DQ3	J1.119	1-bit: Hold 2-bit: Hold 4-bit: I/O3	MIO bank 0, pin 5
SPI0_SCLK	J1.129	Serial clock	MIO bank 0, pin 6

7.2.4 Static memory controller (NAND)

Static memory controller (SMC) signals are routed to the connectors to connect an external flash NAND memory chip.

The following table describes the interface signals:

Pin name	Conn. Pin	Function	Notes
NAND_CS0	J1.122	NAND flash chip select	MIO bank 0, pin 0
NAND_IO0	J1.119	NAND I/O 0	MIO bank 0, pin 5
NAND_IO1	J1.129	NAND I/O 1	MIO bank 0, pin 6
NAND_IO2	J1.121	NAND I/O 2	MIO bank 0, pin 4
NAND_IO3	J1.124	NAND I/O 3	MIO bank 0, pin 13
NAND_IO4	J1.126	NAND I/O 4	MIO bank 0, pin 9
NAND_IO5	J1.128	NAND I/O 5	MIO bank 0, pin 10
NAND_IO6	J1.132	NAND I/O 6	MIO bank 0, pin 11
NAND_IO7	J1.134	NAND I/O 7	MIO bank 0, pin 12
NAND_WE	J1.123	NAND write enable	MIO bank 0, pin 3
NAND_ALE	J1.125	NAND address latch	MIO bank 0, pin 2
NAND_RB	J1.136	NAND ready/busy	MIO bank 0, pin 8
NAND_CLE	J1.138	NAND command latch enable	MIO bank 0, pin 7

7.2.5 I²C0

This I²C module is a bus controller that can function as a master or a slave in a multi-master design. It supports an extremely wide clock frequency range up to 400 Kb/s. I²C0 is internally connected to the following devices:

- Thermal IC (Address: 0x4F)
- RTC (Address: 0x68)

The following table describes the interface signals:

Pin name	Conn. Pin	Function	Notes
PS_I2C0_CK	J1.88	I2C clock	
PS_I2C0_DAT	J1.84	I2C data	

7.2.6 SD/SDIO

The SD/SDIO controller controller is compatible with the

standard SD Host Controller Specification Version 2.0

Part A2. The core also supports up to seven functions in SD1, SD4, but does not support SPI mode. It does support SD high-speed (SDHS) and SD High Capacity (SDHC) card standards. The SD/SDIO controller also supports MMC3.31.

The following table describes the interface signals:

Pin name	Conn. Pin	Function	Notes
PS_SD0_CLOCK	J1.85	SD/SDIO/MMC clock	
PS_SD0_CMD	J1.81	SD/SDIO/MMC command	
PS_SD0_DAT0	J1.79	SD/SDIO/MMC data 0	
PS_SD0_DAT1	J1.77	SD/SDIO/MMC data 1	
PS_SD0_DAT2	J1.75	SD/SDIO/MMC data 2	
PS_SD0_DAT3	J1.73	SD/SDIO/MMC data 3	

7.2.7 UART1

The UART controller is a full-duplex asynchronous receiver and transmitter that supports a wide range of programmable baud rates and I/O signal formats. UART1 port is routed to the SOM connectors as a 2-wire interface.

The following table describes the interface signals:

Pin name	Conn. Pin	Function	Notes
PS_UART1_RX	J1.80	UART Receive line	
PS_UART1_TX	J1.82	UART Transmit line	

7.2.8 CAN

CAN port is connected to on-board transceiver (TI SN65HVD232) which converts the single-ended CAN signals of the controller to the differential signals of the physical layer.

The following table describes the interface signals:

Pin name	Conn. Pin	Function	Notes
CAN_H	J2.107	High bus output	
CAN_L	J2.105	Low bus output	

Optionally, the on-board PHY can be excluded (for example, to use an external PHY on the carrier board) and the single-ended CAN signals are routed to the connectors as described in the following table:

Pin name	Conn. Pin	Function	Notes
CAN_RX	J2.35	Receive data pin	Routed to EMIO (pin IO_L19P_T3_34)
CAN_TX	J2.9	Transmit data pin	Routed to EMIO (pin IO_L6P_T0_34)

Please contact our Sales Department for more information about this hardware option.

7.2.9 JTAG

The Zynq-7000 family of AP SoC devices provides debug access via a standard JTAG (IEEE 1149.1) debug interface. This JTAG port grants access to the device chain composed of both the CPU core and the FPGA part.

The following table describes the interface signals:

Pin name	Conn. Pin	Function	Notes
JTAG_TDO	J2.80	JTAG TDO	
JTAG_TDI	J2.82	JTAG TDI	
JTAG_TMS	J2.84	JTAG TMS	
JTAG_TCK	J2.86	JTAG TCK	

7.3 PL interfaces

The following paragraphs describe in detail the available PL I/O pins and how they are routed to the BORA connectors. The Zynq-7000 AP SoC is split into I/O banks to allow for flexibility in

the choice of I/O standards, thus each table reports one bank configuration. Moreover, BORA design allows carrier board to power two PL banks in order to achieve complete flexibility in terms of I/O voltage levels too.

For more details about PCB design considerations, please refer to chapter 8.

The following table reports the I/O banks characteristics:

FPGA bank	I/O voltage	Voltage pins	Notes
Bank 35	User defined VIO=FPGA_VDDIO_ BANK35 1.8 to 3.3V	J1.2 J1.66 J1.67 J1.68	
Bank 34	Fixed VIO=3.3 V	-	
Bank 13	User defined VIO=FPGA_VDDIO_ BANK13 1.8 to 3.3V	J3.95 J3.96 J3.97 J3.98 J3.99	Bank 13 is available only with Zynq XC7Z020 part number. Although this bank is not available on Bora SOMs equipped with the XC7Z010 SOC, VDDIO_BANK13 pins must not be left open and must be connected anyway, either to ground or to an external I/O voltage.

Each user I/O is labeled IO_LXXY_Tn_ZZZ_ADi_#, where:

- IO indicates a user I/O pin.
- L indicates a differential pair, with XX a unique pair in the bank and Y = [P|N] for the positive/negative sides of the differential pair.
- Tn indicates the memory byte group [0-3]
- ZZZ indicates a MRCC, SRCC or DQS pin
- ADi indicates a XADC (analog-to-digital converter) differential auxiliary analog input [0-15].
- # indicates the bank number.

Rows highlighted like the following one

IO_L19P_T3_34	J2.35	Internally used as CAN_RX
---------------	-------	---------------------------

are related to signals that are used for particular functions into the SOM

7.3.1 FPGA Bank 34

The following table reports the available pins connected to bank 34:

Pin name	Conn. Pin	Notes
IO_0_34	J2.69	
IO_25_34	J2.67	
IO_L10N_T1_34	J2.65	
IO_L10P_T1_34	J2.63	
IO_L11N_T1_SRCC_34	J2.59	
IO_L11P_T1_SRCC_34	J2.57	
IO_L12N_T1_MRCC_34	J2.62	
IO_L12P_T1_MRCC_34	J2.60	
IO_L13N_T2_MRCC_34	N.A.	
IO_L13P_T2_MRCC_34	N.A.	
IO_L14N_T2_SRCC_34	J2.56	
IO_L14P_T2_SRCC_34	J2.54	
IO_L15N_T2_DQS_34	J2.47	
IO_L15P_T2_DQS_34	J2.45	
IO_L16N_T2_34	J2.50	
IO_L16P_T2_34	J2.48	
IO_L17N_T2_34	J2.46	
IO_L17P_T2_34	J2.44	
IO_L18N_T2_34	J2.41	
IO_L18P_T2_34	J2.39	
IO_L19N_T3_VREF_34	J2.37	
IO_L19P_T3_34	J2.35	Internally used as CAN_RX
IO_L1N_T0_34	J2.40	
IO_L1P_T0_34	J2.38	
IO_L20N_T3_34	J2.36	
IO_L20P_T3_34	J2.34	
IO_L21N_T3_DQS_34	J2.31	

Pin name	Conn. Pin	Notes
IO_L21P_T3_DQS_34	J2.29	
IO_L22N_T3_34	J2.27	
IO_L22P_T3_34	J2.25	
IO_L23N_T3_34	J2.30	
IO_L23P_T3_34	J2.28	
IO_L24N_T3_34	J2.26	
IO_L24P_T3_34	J2.24	
IO_L2N_T0_34	J2.21	
IO_L2P_T0_34	J2.19	
IO_L3N_T0_DQS_34	J2.17	
IO_L3P_T0_DQS_PUDC_B_34	J2.15	
IO_L4N_T0_34	J2.20	
IO_L4P_T0_34	J2.18	
IO_L5N_T0_34	J2.16	
IO_L5P_T0_34	J2.14	
IO_L6N_T0_VREF_34	J2.11	Internally used for SOM ID. Connected to a 10kΩ pull-up
IO_L6P_T0_34	J2.9	Internally used as CAN_TX
IO_L7N_T1_34	J2.10	
IO_L7P_T1_34	J2.8	
IO_L8N_T1_34	J2.7	Internally used for SOM ID. Connected to a 10kΩ pull-up
IO_L8P_T1_34	J2.5	Internally used for SOM ID. Connected to a 10kΩ pull-up
IO_L9N_T1_DQS_34	J2.6	
IO_L9P_T1_DQS_34	J2.4	

Regarding power voltage, take into consideration that Bank 35 is fixed at 3.3V.

Routing implemented on BORA SoM allows for using bank 34's signals as differential pairs as well as single-ended lines. Signals are grouped as denoted by the following table that details routing rules on BORA module. No carrier board guidelines can be provided, because these are application-dependent.

Pairs are highlighted with different colors. When used as differential pairs, differential impedance is 100 Ohm. When used as single-ended signals, impedance is 50 Ohm.

Pin name	Individual trace length [mils]	Intra-pair match [mils]	Inter-pair match [mils]	Group name
IO_L1N_T0_34	1751,37	25	300	BANK34 Diff group 1
IO_L1P_T0_34	1749,02	25	300	BANK34 Diff group 1
IO_L2N_T0_34	1625,68	25	300	BANK34 Diff group 1
IO_L2P_T0_34	1624,91	25	300	BANK34 Diff group 1
IO_L4N_T0_34	1581,72	25	300	BANK34 Diff group 1
IO_L4P_T0_34	1582,11	25	300	BANK34 Diff group 1
IO_L5N_T0_34	1769,81	25	300	BANK34 Diff group 1
IO_L5P_T0_34	1776,23	25	300	BANK34 Diff group 1
IO_L7N_T1_34	1566,52	25	300	BANK34 Diff group 1
IO_L7P_T1_34	1569,36	25	300	BANK34 Diff group 1
IO_L9N_T1_DQS_34	1490,25	25	300	BANK34 Diff group 1
IO_L9P_T1_DQS_34	1498,04	25	300	BANK34 Diff group 1
IO_L10N_T1_34	1516,97	25	300	BANK34 Diff group 1
IO_L10P_T1_34	1517,37	25	300	BANK34 Diff group 1
IO_L15N_T2_DQS_34	1610,74	25	300	BANK34 Diff group 1
IO_L15P_T2_DQS_34	1602,81	25	300	BANK34 Diff group 1
IO_L16N_T2_34	1601,55	25	300	BANK34 Diff group 1
IO_L16P_T2_34	1616,03	25	300	BANK34 Diff group 1
IO_L17N_T2_34	1574,33	25	300	BANK34 Diff group 1
IO_L17P_T2_34	1593,38	25	300	BANK34 Diff group 1
IO_L18N_T2_34	1740,11	25	300	BANK34 Diff group 1
IO_L18P_T2_34	1750,54	25	300	BANK34 Diff group 1
IO_L20N_T3_34	1588,01	25	300	BANK34 Diff group 1
IO_L20P_T3_34	1585,53	25	300	BANK34 Diff group 1
IO_L21N_T3_DQS_34	1567,1	25	300	BANK34 Diff group 1
IO_L21P_T3_DQS_34	1570,96	25	300	BANK34 Diff group 1
IO_L22N_T3_34	1619,26	25	300	BANK34 Diff group 1
IO_L22P_T3_34	1622,13	25	300	BANK34 Diff group 1
IO_L23N_T3_34	1769,71	25	300	BANK34 Diff group 1
IO_L23P_T3_34	1775,52	25	300	BANK34 Diff group 1
IO_L24N_T3_34	1772,07	25	300	BANK34 Diff group 1
IO_L24P_T3_34	1774,49	25	300	BANK34 Diff group 1

Pin name	Individual trace length [mils]	Intra-pair match [mils]	Inter-pair match [mils]	Group name
IO_L11N_T1_SRCC_34	1817,43	10	50	BANK34 xRCC group
IO_L11P_T1_SRCC_34	1823,90	10	50	BANK34 xRCC group
IO_L12N_T1_MRCC_34	1844,20	10	50	BANK34 xRCC group
IO_L12P_T1_MRCC_34	1841,36	10	50	BANK34 xRCC group
IO_L13N_T1_MRCC_34	1811,51	10	50	BANK34 xRCC group
IO_L13P_T1_MRCC_34	1818,58	10	50	BANK34 xRCC group
IO_L14N_T2_SRCC_34	1818,78	10	50	BANK34 xRCC group
IO_L14P_T2_SRCC_34	1822,02	10	50	BANK34 xRCC group

7.3.2 FPGA Bank 35

The following table reports the available pins connected to bank 35:

Pin name	Conn. Pin	Notes
IO_0_35	J1.74	
IO_25_35	J1.18	
IO_L10N_T1_AD11N_35	J1.6	
IO_L10P_T1_AD11P_35	J1.5	
IO_L11N_T1_SRCC_35	J1.10	
IO_L11P_T1_SRCC_35	J1.7	
IO_L12N_T1_MRCC_35	J1.27	
IO_L12P_T1_MRCC_35	J1.8	
IO_L13N_T2_MRCC_35	J1.39	
IO_L13P_T2_MRCC_35	J1.40	
IO_L14N_T2_AD4N_SRCC_35	J1.36	
IO_L14P_T2_AD4P_SRCC_35	J1.34	
IO_L15N_T2_DQS_AD12N_35	J1.47	
IO_L15P_T2_DQS_AD12P_35	J1.46	
IO_L16N_T2_35	J1.44	
IO_L16P_T2_35	J1.45	
IO_L17N_T2_AD5N_35	J1.37	

Pin name	Conn. Pin	Notes
IO_L17P_T2_AD5P_35	J1.32	
IO_L18N_T2_AD13N_35	J1.42	
IO_L18P_T2_AD13P_35	J1.43	
IO_L19N_T3_VREF_35	J1.64	
IO_L19P_T3_35	J1.41	
IO_L1N_T0_AD0N_35	J1.53	
IO_L1P_T0_AD0P_35	J1.50	
IO_L20N_T3_AD6N_35	J1.23	
IO_L20P_T3_AD6P_35	J1.21	
IO_L21N_T3_DQS_AD14N_35	J1.33	
IO_L21P_T3_DQS_AD14P_35	J1.31	
IO_L22N_T3_AD7N_35	J1.26	
IO_L22P_T3_AD7P_35	J1.25	
IO_L23N_T3_35	J1.22	
IO_L23P_T3_35	J1.28	
IO_L24N_T3_AD15N_35	J1.16	
IO_L24P_T3_AD15P_35	J1.20	
IO_L2N_T0_AD8N_35	J1.51	
IO_L2P_T0_AD8P_35	J1.52	
IO_L3N_T0_DQS_AD1N_35	J1.63	
IO_L3P_T0_DQS_AD1P_35	J1.61	
IO_L4N_T0_35	J1.54	
IO_L4P_T0_35	J1.56	
IO_L5N_T0_AD9N_35	J1.55	
IO_L5P_T0_AD9P_35	J1.57	
IO_L6N_T0_VREF_35	J1.62	
IO_L6P_T0_35	J1.58	
IO_L7N_T1_AD2N_35	J1.11	
IO_L7P_T1_AD2P_35	J1.3	
IO_L8N_T1_AD10N_35	J1.9	
IO_L8P_T1_AD10P_35	J1.12	
IO_L9N_T1_DQS_AD3N_35	J1.17	

Pin name	Conn. Pin	Notes
IO_L9P_T1_DQS_AD3P_35	J1.15	

On BORA side, routing of bank 35 has been optimized to interface 16-bit DDR3 SDRAM memory devices, clocked at a maximum frequency of 400 MHz. Signals have been grouped in the following classes:

- FDDR_ADDR
- FDDR_CK
- FDDR_BYTE0
- FDDR_BYTE1

Some of them are differential pairs. These kind of signals are highlighted in dark gray in the following sections where, for each signal, detailed information are provided, related to routing rules implemented on BORA SoM and carrier board guidelines.

The tables in the following sections report general recommended rules for single-ended and differential pairs on carrier board in terms of impedance and isolation.

Regarding power voltage, Bank 35 is configurable and must be powered by carrier board.

Please note that some signals belonging to this bank can be configured alternatively as XADC auxiliary analog inputs.

7.3.2.1 Differential pairs

	Value	UOM
Common Mode impedance typ	55	Ohm
Differential Mode impedance typ	100	Ohm
Isolation	4x	gap

7.3.2.2 Single-ended signals

	Value	UOM
Common Mode impedance typ	55	Ohm
Isolation	2x	width

7.3.2.3 FDDR_ADDR class

The following table details routing rules implemented on BORA SoM and suggested carrier board guidelines for FDDR_ADDR class signals. The following picture shows the connection scheme and the nomenclature used in the table.

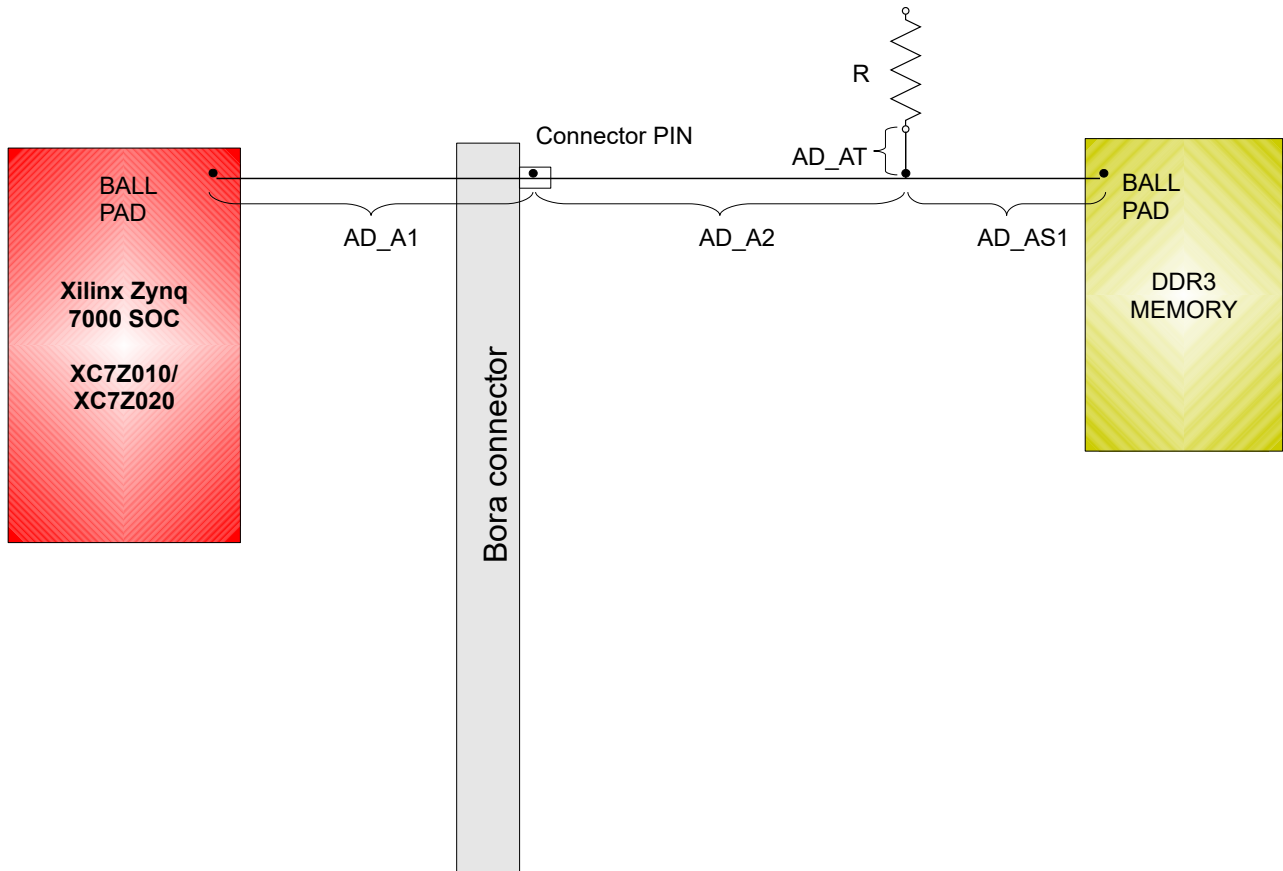

Pin Name	Group Name	Carrier board net name	SoM routing rules and specifications			Carrier board guidelines					
			Actual length [mils]	Max length match [mils]	Nominal max length [mils]	AD_A2 length match [mils]	AD_AT length match [mils]	AD_AS1 length match [mils]	AD_AS1 max length [mils]	AD_AT max length [mils]	AD_A2+AD_AS1 max length [mils]
IO L17N T2 AD5N 35	FDDR_ADDR	FDDR_ADDR 3	1832	80	1912	40	100	50	60	400	2100
IO L20P T3 AD6P 35	FDDR_ADDR	FDDR BA 2	1853,4	80	1912	40	100	50	60	400	2100
IO L16N T2 35	FDDR_ADDR	FDDR_ADDR_5	1832	80	1912	40	100	50	60	400	2100
IO L18N T2 AD13N 35	FDDR_ADDR	FDDR_ADDR 1	1832	80	1912	40	100	50	60	400	2100
IO L24N T3 AD15N 35	FDDR_ADDR	FDDR_CKE 0	1834,3	80	1912	40	100	50	60	400	2100
IO L23P T3 35	FDDR_ADDR	FDDR_CAS N	1857,01	80	1912	40	100	50	60	400	2100
IO L14N T2 AD4N SRCC 35	FDDR_ADDR	FDDR_ADDR 9	1832	80	1912	40	100	50	60	400	2100
IO L24P T3 AD15P 35	FDDR_ADDR	FDDR_CS0 N	1832	80	1912	40	100	50	60	400	2100
IO L14P T2 AD4P SRCC 35	FDDR_ADDR	FDDR_ADDR 10	1832	80	1912	40	100	50	60	400	2100
IO L15P T2 DQS AD12P 35	FDDR_ADDR	FDDR_ADDR 8	1832	80	1912	40	100	50	60	400	2100
IO L15N T2 DQS AD12N 35	FDDR_ADDR	FDDR_ADDR 7	1832	80	1912	40	100	50	60	400	2100
IO L12N T1 MRCC 35	FDDR_ADDR	FDDR_RESET N	1832	80	1912	40	100	50	60	400	2100
IO L13P T2 MRCC 35	FDDR_ADDR	FDDR_ADDR 12	1832	80	1912	40	100	50	60	400	2100
IO L13N T2 MRCC 35	FDDR_ADDR	FDDR_ADDR 11	1832	80	1912	40	100	50	60	400	2100
IO 25 35	FDDR_ADDR	FDDR_ODT 0	1832	80	1912	40	100	50	60	400	2100
IO L23N T3 35	FDDR_ADDR	FDDR_WE N	1869,66	80	1912	40	100	50	60	400	2100
IO L17P T2 AD5P 35	FDDR_ADDR	FDDR_ADDR 4	1832	80	1912	40	100	50	60	400	2100
IO L22N T3 AD7N 35	FDDR_ADDR	FDDR_RAS N	1832	80	1912	40	100	50	60	400	2100
IO L20N T3 AD6N 35	FDDR_ADDR	FDDR_BA 1	1832	80	1912	40	100	50	60	400	2100
IO L18P T2 AD13P 35	FDDR_ADDR	FDDR_ADDR 2	1853,7	80	1912	40	100	50	60	400	2100
IO L16P T2 35	FDDR_ADDR	FDDR_ADDR 6	1832	80	1912	40	100	50	60	400	2100
IO L22P T3 AD7P 35	FDDR_ADDR	FDDR_BA 0	1850,82	80	1912	40	100	50	60	400	2100
IO L19P T3 35	FDDR_ADDR	FDDR_ADDR 0	1836,73	80	1912	40	100	50	60	400	2100

7.3.2.4 FDDR_CK class

The Following table details routing rules implemented on BORA SoM and suggested carrier board guidelines for FDDR_CK class signals. The following picture shows the connection scheme and the nomenclature used in the table.

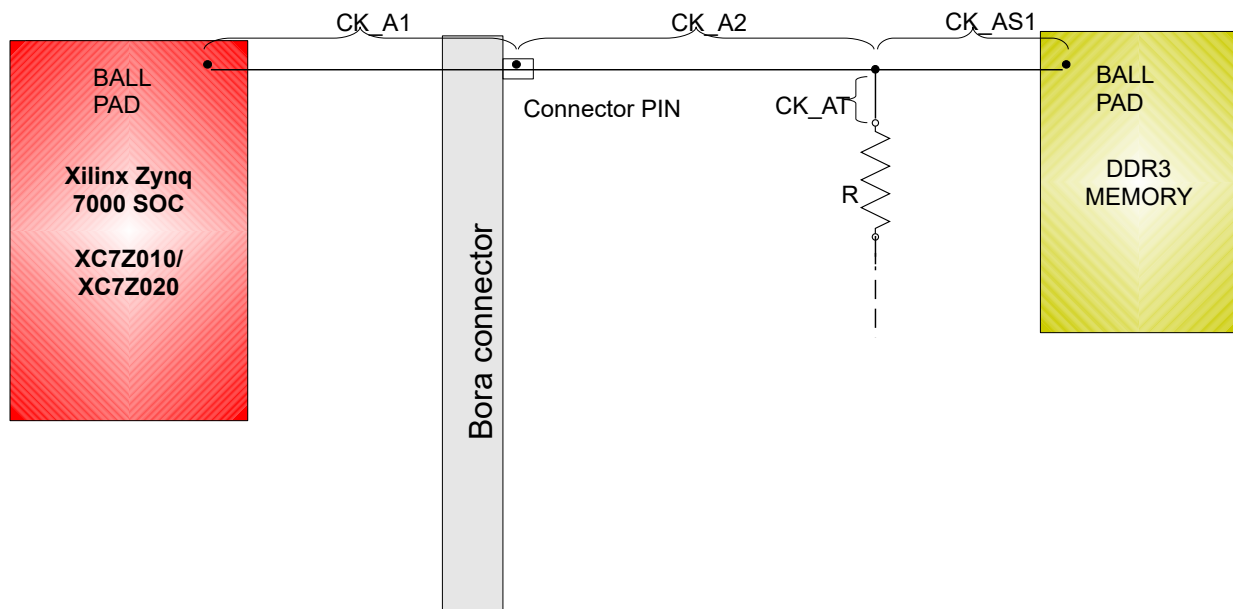

Pin Name	Group Name	Carrier board net name	SoM routing rules and specifications				Carrier board guidelines							
			Actual length [mils]	Intra-pair match [mils]	Max length match ⁽¹⁾ [mils]	Nominal max length [mils]	Intra-pair match [mils]	CK_A2 pair match ⁽²⁾ [mils]	CK_AT intra-pair match [mils]	CK_AS1 match ⁽²⁾ [mils]	CK_AS1 max length [mils]	CK_AT maximum length [mils]	CK_AT pair match ⁽²⁾ [mils]	CK_A2+CK_AS1 max length [mils]
IO_L21P_T3_DQS_AD14 P_35	FDDR_CK	FDDR_CK_P0	1900,39	5	80	1912	10	40	5	50	60	400	100	2100
IO_L21N_T3_DQS_AD14 N_35	FDDR_CK	FDDR_CK_N0	1898,17	5	80	1912	10	40	5	50	60	400	100	2100

¹: with respect to FDDR_ADDR group

²: with respect to FDDR_ADDR

7.3.2.5 FDDR_BYTE0 class

The following table details routing rules implemented on BORA SoM and suggested carrier board guidelines for FDDR_BYTE0 class signals.

Pin Name	Group name	Carrier board net name	SoM routing rules and specifications				Carrier board guidelines		
			Actual length [mils]	Max length match [mils]	Max inter-pair match length on SOM [mils]	Nominal max length [mils]	Group match (mandatory) [mils]	Intra-pair match (mandatory) [mils]	Max length [mils]
IO_L2N_T0_AD8N_35	FDDR_BYTE0	FDDR_DQ_2	1222,66	15	-	1230	25	-	CK_A2+CK_AS1(max)
IO_L6P_T0_35	FDDR_BYTE0	FDDR_DQ_7	1219,68	15	-	1230	25	-	CK_A2+CK_AS1(max)
IO_L5P_T0_AD9P_35	FDDR_BYTE0	FDDR_DQ_5	1226,42	15	-	1230	25	-	CK_A2+CK_AS1(max)
IO_L4P_T0_35	FDDR_BYTE0	FDDR_DQ_3	1219,68	15	-	1230	25	-	CK_A2+CK_AS1(max)
IO_L2P_T0_AD8P_35	FDDR_BYTE0	FDDR_DQ_1	1219,68	15	-	1230	25	-	CK_A2+CK_AS1(max)
IO_L1N_T0_AD0N_35	FDDR_BYTE0	FDDR_DQ_0	1219,68	15	-	1230	25	-	CK_A2+CK_AS1(max)
IO_L4N_T0_35	FDDR_BYTE0	FDDR_DQ_4	1219,68	15	-	1230	25	-	CK_A2+CK_AS1(max)
IO_L5N_T0_AD9N_35	FDDR_BYTE0	FDDR_DQ_6	1219,68	15	-	1230	25	-	CK_A2+CK_AS1(max)
IO_L1P_T0_AD0P_35	FDDR_BYTE0	FDDR_DM_0	1219,68	15	-	1230	25	-	CK_A2+CK_AS1(max)
IO_L3P_T0_DQS_AD1P_35	FDDR_BYTE0	FDDR_DQS_P0	1221,04	15	5	1230	25	5	CK_A2+CK_AS1(max)

Pin Name	Group name	Carrier board net name	SoM routing rules and specifications				Carrier board guidelines		
			Actual length [mils]	Max length match [mils]	Max inter-pair match length on SOM [mils]	Nominal max length [mils]	Group match (mandatory) [mils]	Intra-pair match (mandatory) [mils]	Max length [mils]
IO_L3N_T0_DQS_AD1N_35	FDDR_BYTE0	FDDR_DQS_N0	1219,42	15	5	1230	25	5	CK_A2+CK_AS1(max)

7.3.2.6 FDDR_BYTE1 class

The following table details routing rules implemented on BORA SoM and suggested carrier board guidelines for FDDR_BYTE1 class signals.

Pin Name	Group name	Carrier board net name	SoM routing rules and specifications				Carrier board guidelines		
			Actual length [mils]	Max length match [mils]	Max inter-pair match length on SOM [mils]	Nominal max length [mils]	Group match (mandatory) [mils]	Intra-pair match (mandatory) [mils]	Max length [mils]
IO_L10N_T1_AD11N_35	FDDR_BYTE1	FDDR_DQ_12	1345,93	15	-	1355	20	-	CK_A2+CK_AS1(max)
IO_L10P_T1_AD11P_35	FDDR_BYTE1	FDDR_DQ_11	1345,93	15	-	1355	20	-	CK_A2+CK_AS1(max)
IO_L11P_T1_SRCC_35	FDDR_BYTE1	FDDR_DQ_13	1353,43	15	-	1355	20	-	CK_A2+CK_AS1(max)
IO_L12P_T1_MRCC_35	FDDR_BYTE1	FDDR_DQ_15	1341,3	15	-	1355	20	-	CK_A2+CK_AS1(max)
IO_L11N_T1_SRCC_35	FDDR_BYTE1	FDDR_DQ_14	1340	15	-	1355	20	-	CK_A2+CK_AS1(max)
IO_L8P_T1_AD10P_35	FDDR_BYTE1	FDDR_DQ_9	1340	15	-	1355	20	-	CK_A2+CK_AS1(max)
IO_L7N_T1_AD2N_35	FDDR_BYTE1	FDDR_DQ_8	1340	15	-	1355	20	-	CK_A2+CK_AS1(max)
IO_L8N_T1_AD10N_35	FDDR_BYTE1	FDDR_DQ_10	1340	15	-	1355	20	-	CK_A2+CK_AS1(max)
IO_L7P_T1_AD2P_35	FDDR_BYTE1	FDDR_DM_1	1345,93	15	-	1355	20	-	CK_A2+CK_AS1(max)
IO_L9P_T1_DQS_AD3P_35	FDDR_BYTE1	FDDR_DQS_P1	1354,26	15	5	1355	20	5	CK_A2+CK_AS1(max)
IO_L9N_T1_DQS_AD3N_35	FDDR_BYTE1	FDDR_DQS_N1	1350,66	15	5	1355	20	5	CK_A2+CK_AS1(max)

7.3.2.7 VREF

Please keep to the following recommendations:

- use a "T" connection as shown by following picture
- use 20+ mils trace
- place bypass capacitors as close as possible to power balls.

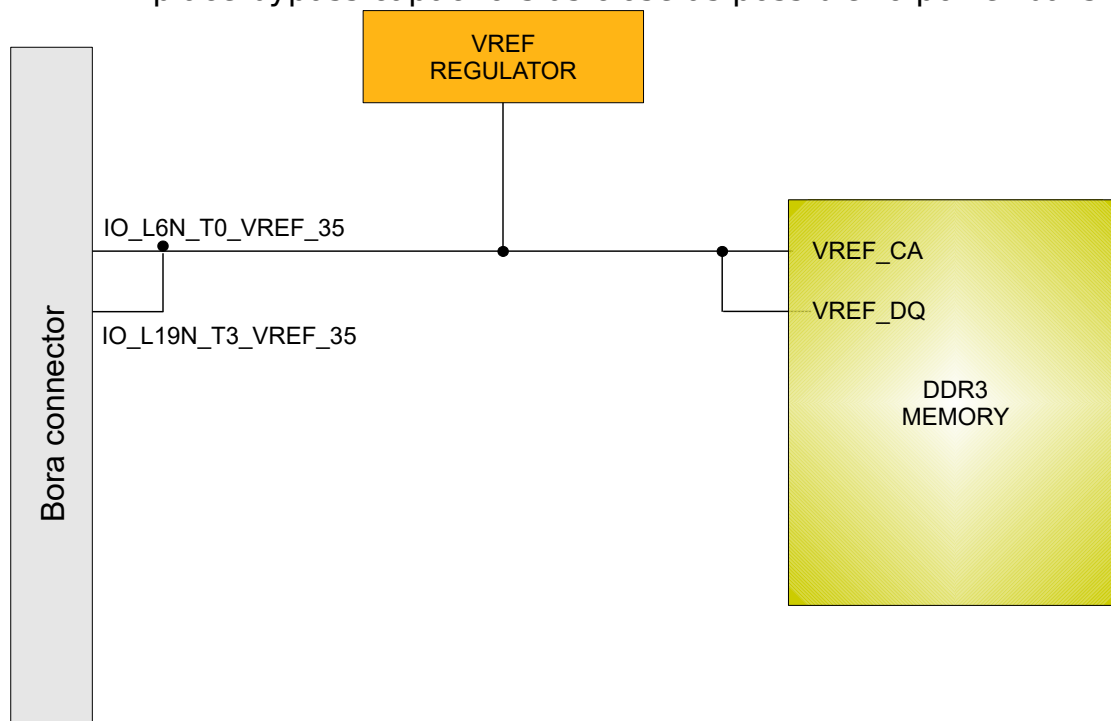

7.3.2.8 Related Xilinx documentation

For further information, please refer to the following documents:

Document	Location
Xilinx Memory Interface Solutions UG586	http://www.xilinx.com/support/documentation/ip_documentation/mig_7series/v2_0/ug586_7Series_MIS.pdf
Xilinx Memory Interface Solutions Data Sheet	http://www.xilinx.com/support/documentation/ip_documentation/mig_7series/v2_0/ds176_7Series_MIS.pdf

7.3.3 FPGA Bank 13 (Zynq 7020 only)

N.B. Although BANK 13 is not available on Bora SOMs equipped with the XC7Z010 SOC, VDDIO_BANK13 pins must not be left open and must be connected anyway, either to ground or to an external I/O voltage.

The following table reports the available pins connected to bank 13:

Pin name	Conn. Pin	Notes
IO_L11N_T1_SRCC_13	J3.136	
IO_L11P_T1_SRCC_13	J3.134	
IO_L12N_T1_MRCC_13	J3.137	
IO_L12P_T1_MRCC_13	J3.135	
IO_L13N_T2_MRCC_13	J3.130	
IO_L13P_T2_MRCC_13	J3.128	
IO_L14N_T2_SRCC_13	J3.131	
IO_L14P_T2_SRCC_13	J3.129	
IO_L15N_T2_DQS_13	J3.124	
IO_L15P_T2_DQS_13	J3.122	
IO_L16N_T2_13	J3.125	
IO_L16P_T2_13	J3.123	
IO_L17N_T2_13	J3.118	
IO_L17P_T2_13	J3.116	
IO_L18N_T2_13	J3.119	
IO_L18P_T2_13	J3.117	
IO_L19N_T3_VREF_13	J3.113	
IO_L19P_T3_13	J3.111	
IO_L20N_T3_13	J3.112	
IO_L20P_T3_13	J3.110	
IO_L21N_T3_DQS_13	J3.107	
IO_L21P_T3_DQS_13	J3.105	
IO_L22N_T3_13	J3.106	
IO_L22P_T3_13	J3.104	

Pin name	Conn. Pin	Notes
IO_L6N_T0_VREF_13	J3.100	

Regarding power voltage, Bank 13 is configurable and must be powered by carrier board.

Routing implemented on BORA SoM allows the use of bank 13's signals as differential pairs as well as single-ended lines. Signals are grouped as denoted by the following table that details routing rules on BORA module. No carrier board guidelines can be provided, because these are application-dependent.

Pairs are highlighted with different colors. When used as differential pairs, differential impedance is 100 Ohm. When used as single-ended signals, impedance is 50 Ohm.

Pin name	Individual trace length [mils]	Intra-pair match [mils]	Inter-pair match [mils]	Group name
IO_L15N_T2_DQS_13	1582,37	25	200	BANK13 Diff group 1
IO_L15P_T2_DQS_13	1602,37	25	200	BANK13 Diff group 1
IO_L16N_T2_13	1589,32	25	200	BANK13 Diff group 1
IO_L16P_T2_13	1602,33	25	200	BANK13 Diff group 1
IO_L17N_T2_13	1710,41	25	200	BANK13 Diff group 1
IO_L17P_T2_13	1722,73	25	200	BANK13 Diff group 1
IO_L18N_T2_13	1720,53	25	200	BANK13 Diff group 1
IO_L18P_T2_13	1712,11	25	200	BANK13 Diff group 1
IO_L19N_T3_VREF_13	1585,55	25	200	BANK13 Diff group 1
IO_L19P_T3_13	1602,96	25	200	BANK13 Diff group 1
IO_L20N_T3_13	1623,95	25	200	BANK13 Diff group 1
IO_L20P_T3_13	1626,27	25	200	BANK13 Diff group 1
IO_L21N_T3_DQS_13	1661,55	25	200	BANK13 Diff group 1
IO_L21P_T3_DQS_13	1668,95	25	200	BANK13 Diff group 1
IO_L22N_T3_13	1592,18	25	200	BANK13 Diff group 1
IO_L22P_T3_13	1577,63	25	200	BANK13 Diff group 1
IO_L11N_T1_SRCC_13	1702,04	10	50	BANK13 xRCC group
IO_L11P_T1_SRCC_13	1705,07	10	50	BANK13 xRCC group
IO_L12N_T1_MRCC_13	1704,42	10	50	BANK13 xRCC group

Pin name	Individual trace length [mils]	Intra-pair match [mils]	Inter-pair match [mils]	Group name
IO_L12P_T1_MRCC_13	1703,11	10	50	BANK13 xRCC group
IO_L13N_T2_MRCC_13	1731,33	10	50	BANK13 xRCC group
IO_L13P_T2_MRCC_13	1732,15	10	50	BANK13 xRCC group
IO_L14N_T2_SRCC_13	1710,12	10	50	BANK13 xRCC group
IO_L14P_T2_SRCC_13	1716,36	10	50	BANK13 xRCC group

8 Carrier board design guidelines

Generally speaking, when designing a system-on-module (SoM) product it is impossible to know in advance the combination of interfaces and functionalities that will be implemented by the system integrator. This is even more true in case of BORA, due to the unprecedented flexibility and versatility of Zynq architecture. For this reason, BORA implements advanced routing schemes that, in combination with proper carrier board design, allow the implementation of high-speed complex interfaces that satisfy signal integrity requirements.

This chapter describes in detail such schemes and provides carrier board design guidelines accordingly. These information complement SoM-independent recommendations provided in [http://wiki.dave.eu/index.php/Carrier_board_design_guidelines_\(SOM\)](http://wiki.dave.eu/index.php/Carrier_board_design_guidelines_(SOM)).

In the following section the terms "Inter-pair matching" and "Intra-pair matching" are used. They indicate respectively:

- length matching among pairs belonging to the same class or group
- length matching between traces belonging to the same pair.

8.1 Suggested PCB specifications

	Min	Typ
Layers (number)	4	6
GND Plane Layers	1	2
Power Plane Layers	1	1
Vias hole (mechanical) ⁴ [mm]	0.3	-

8.2 Power rails

Following power rails should be kept as short as possible and should be sized in order to minimize IR drop at maximum estimated current:

4 Smaller holes are deprecated because of their limited current capacity and heat dissipation.

Rails	Max estimated current	Required plane or copper areas
3.3V_SOM	Application dependent	6
VDDIO_BANK35	Application dependent	2
VDDIO_BANK13	Application dependent	1

8.3 Main SD/MMC interface

Signals: PS_MIO40_501, PS_MIO41_501, PS_MIO42_501, PS_MIO43_501, PS_MIO44_501, PS_MIO45_501.

The following table details routing rules implemented on BORA SoM:

	Value	UOM
Common Mode impedance	50	Ohm
Maximum Length Tolerance	200	mils

8.4 Main Gigabit Ethernet interface (ETH0)

Signals: ETH_TXRX0_P/ETH_TXRX0_M,
ETH_TXRX1_P/ETH_TXRX1_M,
ETH_TXRX2_P/ETH_TXRX2_M,
ETH_TXRX3_P/ETH_TXRX3_M.

Following table details routing rules implemented on BORA SoM.

	Value	UOM
Common Mode impedance SOM	55	Ohm
Differential Mode impedance SOM	100	Ohm
Maximum Length Tolerance on SOM (intra-pair)	10	mils
Maximum Length Tolerance on SOM (inter-pair)	400	mils

8.5 CAN interface

Signals: CAN_H/CAN_L

The following table details routing rules implemented on BORA SoM.

	Value	UOM
Common Mode impedance SOM	-	Ohm
Differential Mode impedance SOM	110	Ohm
Maximum Length Tolerance on SOM (intra-pair)	-	mils
Maximum Length Tolerance on SOM (inter-pair)	-	mils

8.6 XADC interface

Signals: XADC_VP_R/XADC_VN_R (dedicated analog inputs).

Following table details routing rules implemented on BORA SoM.

	Value	UOM
Differential Mode impedance typ	100	Ohm
Maximum Length Tolerance on SOM(intra-pair)	-	mils
Maximum Length Tolerance on SOM(inter-pair)	-	mils
Intra-pair Matching required	10	

9 Operational characteristics

9.1 Maximum ratings

This section will be completed in a future version of this manual.

Parameter	Min	Typ	Max	Unit
Main power supply voltage	3.14	3.3	3.46	V

9.2 Recommended ratings

This section will be completed in a future version of this manual.

Parameter	Min	Typ	Max	Unit
Main power supply voltage	-	3.3	-	V

9.3 Power consumption

Providing theoretical maximum power consumption value would be useless for the majority of system designers building their application upon BORA module because, in most cases, this would lead to an over-sized power supply unit.

Several configurations have been tested in order to provide figures that are measured on real-world use cases instead. Please note that BORA platform is so flexible that it is virtually impossible to test for all possible configurations and applications on the market. The use cases here presented should cover most of real-world scenarios. However actual customer application might require more power than values reported here. Generally speaking, application specific requirements have to be taken into consideration in order to size power supply unit and to implement thermal management properly.

9.3.1 Testbed 1

Measurements have been performed on the following platform:

- Bora SOM: DBRD511011R
 - this model is based on Zynq XC7Z020-1I (Tj: **-40°C / +100°C**)
- carrier board: [BoraEVB](#)
- processor frequency: **667 MHz**
- FPGA frequency
 - 30 MHz (Tamb = +85°C)
 - 150 MHz (Tamb = +-40°C)
- U-Boot: 2014.07-00067-g4b98484 (Oct 24 2014 - 17:28:32) [belk-2.1.0]
- Linux kernel: 3.15.0-bora-2.1.0-xilinx-00044-g372fcab #5 SMP PREEMPT Thu Oct 23 13:54:38 CEST 2014 armv7l GNU/Linux
- root file system mounted over Gigabit Ethernet link.

Please note that, when Tamb has been set to +85°C, the Bora SOM has been coupled to a passive heat sink to prevent exceeding maximum Zynq's junction temperature.

At the application level, PS executes concurrently several tasks including:

- two instances of [burnCortexA9](#)
- periodic reading of I2C RTC (Maxim DS3232M)
- periodic reading of Zynq's ADCs
- periodic reading of voltage/current probe (Texas Instruments INA226) connected to the SOM's power rail
- one instance of [memtester](#), exercising 50 MByte of SDRAM
- endless loop of writing/reading/verifying operations on microSD card
- periodic reading of I2C remote temperature sensor (Texas Instruments TMP421)
- endless loop of writing/reading/verifying operations on memory stick connected to the USB port.

9.3.1.1 Results

- **Tamb**: temperature of the ambient surrounding the DUT
- **Tj_max**: maximum Zynq's junction temperature measured during the test
- **P_max**: maximum power absorption of Bora SOM

Tamb [°C]	Tj_max [°C]	FPGA clock frequency [MHz]	P_max [W]
85	123.7 [1]	30	5.7
-40	22.8	150	7.0

[1] In spite of the use of heat sink, this value exceeds maximum valued declared by the manufacturer. This is acceptable in case of stress tests, where it is possible that parts of the DUT get damaged.

9.3.2 Testbed 2

Measurements have been performed on the following platform:

- Bora SOM: DBRF5110C1R
 - this model is based on Zynq XC7Z020-3E (Tj: **0 / +100°C**)
- carrier board: [BoraEVB](#)
- processor frequency: **867 MHz**
- FPGA frequency
 - 10 MHz (Tamb = +75°C)
 - 150 MHz (Tamb = +-40°C)
- U-Boot: 2014.07-00068-g9070bdc (Oct 28 2014 - 10:18:52) [belk-2.1.0]
- Linux kernel: 3.15.0-bora-2.1.0-xilinx-00044-g372fcab #5 SMP PREEMPT Thu Oct 23 13:54:38 CEST 2014 armv7l GNU/Linux
- root file system mounted over Gigabit Ethernet link.

Please note that, when Tamb has been set to +75°C, the Bora SOM has been coupled to a fan-cooled heat sink to prevent exceeding maximum Zynq's junction temperature.

At application level, PS executes concurrently several tasks including:

- two instances of [burnCortexA9](#)
- periodic reading of I2C RTC (Maxim DS3232M)
- periodic reading of Zynq's ADCs
- periodic reading of voltage/current probe (Texas Instruments INA226) connected to the SOM's power rail
- one instance of [memtester](#), exercising 50 MByte of SDRAM
- endless loop of writing/reading/verifying operations on microSD card
- periodic reading of I2C remote temperature sensor (Texas Instruments TMP421)
- endless loop of writing/reading/verifying operations on memory stick connected to USB port.

9.3.2.1 Results

- **Tamb**: temperature of the ambient surrounding the DUT
- **Tj_max**: maximum Zynq's junction temperature measured during the test

- **P_max**: maximum power absorption of Bora SOM

Tamb [°C]	Tj_max [°C]	FPGA clock frequency [MHz]	P_max [W]
75	100.8	10	4.1
-40	34.7	150	7.3

9.4 Heat Dissipation

Bora product is designed to support the maximum available temperature range declared by the manufacturer.

The customer shall define and conduct a reasonable number of tests and verification in order to qualify the DUT capabilities to manage the heat dissipation.

For example, in the previous test cases:

- Testbed 1 : when Tamb has been set to +85°C, the Bora SOM has been coupled to a passive heat sink to prevent exceeding maximum Zynq's junction temperature
- Testbed 2 : when Tamb has been set to +75°C, the Bora SOM has been coupled to a fan-cooled heat sink to prevent exceeding maximum Zynq's junction temperature

Any heatsink, fan etc shall be defined case by case depending on the various use conditions like: air cooling (forced or not), enclosure dimensions, mechanical/thermal coupling with heatsink.

A proper thermal analysis must be investigated on the real use scenario which depends on FPGA design, frequency configurations, working signals, etc.

10 Application notes

Please refer to the following documents available on **DAVE Embedded Systems** Developers Wiki:

Document	Location
Integration Guide	http://wiki.dave.eu/index.php/Integration_guide_%28Bora%29
Carrier board design guidelines	http://wiki.dave.eu/index.php/Carrier_board_design_guidelines_%28SOM%29
BELK application notes	http://wiki.dave.eu/index.php/Application_Notes_%28Bora%29