

VSP pressure sensor

For oil-pressure applications



Product description



As one of our smallest pressure sensors, the VSP stands out in particular for its robust and submersible design, which makes it a reliable solution for any oil-pressure application in motor vehicles and commercial vehicles.

Measurements of absolute or relative pressures in a rated pressure range up to 600 bar are possible with the VSP. Its specially developed evaluation electronics permit highly accurate and stable measurements at temperatures up to 150 °C, even under harsh conditions. In addition, the VSP meets the high EMC and ESD requirements that apply in the automotive industry.

The automatic assembly machines can be flexibly adjusted, allowing individually tailored production of the sensor and optimum adaptation to the respective application.

Fields of application

- Oil-pressure applications in motor vehicles and commercial vehicles
 - Braking systems
 - Powertrain
- Measuring and testing technology

Features

Robust and minimised design

- Submersible and oil-resistant version available
- Compatible with standard automotive oils
- Suitable for applications where space is critical
- Also available with lightweight aluminium housing

Specially developed measuring element and evaluation electronics

- High-precision version available
- Can be used at temperatures up to 150 °C

- Reliable, stable measurements over the entire service life
- Tried-and-tested automotive EMC/ESD resistance

Variety of electrical connections and output signals available

- Simple and flexible integration, even into existing systems

VSP pressure sensor

For oil-pressure applications



Technical Specifications

Measurement range

Nominal pressure	0.2–50 bar, absolute 0.2–600 bar, relative ¹⁾
Over pressure	2 × nominal pressure
Burst pressure	3 × nominal pressure
Pressure type	Relative and absolute pressure

Electrical characteristics

Supply voltage	9–30 V, 12–30 V, 5 ± 0.5 V
Current consumption	typ. 10 mA
Output signals	0–5 V, 1–6 V, 0–10 V 0.5–4,5 V (ratiometric)
Overvoltage protection ²⁾	± 30 V
Reverse-polarity resistance ²⁾	± 30 V

Mechanical characteristics

Measuring element	Stainless steel silicon (also with stainless-steel membrane and oil reservoir)
Housing material	Stainless steel, aluminium
Pressure connection	SW 19, M10×1, G1/4"
Thread	Male thread ³⁾

Dimensions

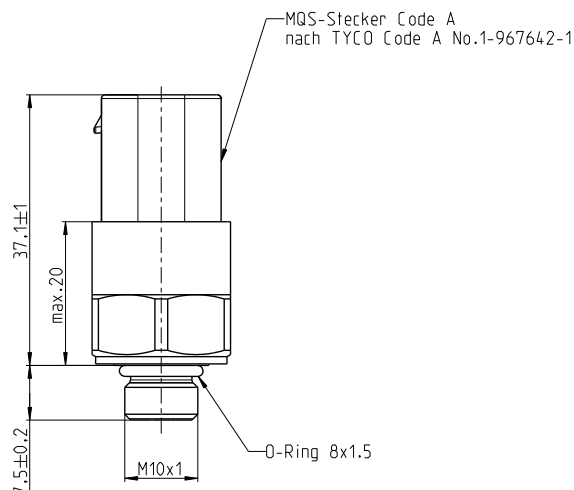

Electrical connection	MQS plug, Packard plug, M12×1 plug ³⁾
Installation position	Any
Weight	approx. 30 g (stainless steel) approx. 15 g (aluminium)

Accuracy

Total error (default) ⁴⁾	± 1 % FS (0–90 °C) ± 2 % FS (–40–125 °C)
Total error (high accuracy) ⁴⁾	± 0.2 % FS

Environmental conditions

Operating temperature range	–40–125 °C (150 °C)
Media temperature range	–40–125 °C (150 °C)
Media compatibility	Engine and transmission oils, various liquid and gaseous media

- ¹⁾ – 1 bar as initial value of relative pressure possible
- ²⁾ Depending on the output signal and the application
- ³⁾ Other pressure connections and electrical connections available on request
- ⁴⁾ Includes repeatability, hysteresis, non-linearity (TBL), calibration and temperature effects; depending on the pressure and temperature range

